



Mayor & City Council

Regular Session Meeting

City of College Park
3667 Main Street
College Park, GA 30337

<http://www.collegeparkga.com>
404-669-3756 (Main)

Experience College Park
Georgia's Global City

~ Agenda ~

Tuesday, September 7, 2021

7:30 PM

Council Chambers

1. Opening Ceremonies
 - A. ***Pledge Of Allegiance***
 - B. ***Invocation***
2. Additions, Deletions, Amendments, or Changes to the Agenda
3. Presentation of Minutes of City Council

A. Approval of Regular Session Minutes dated August 16, 2021

ACTION:

B. Approval of Workshop Session Minutes dated August 16, 2021.

ACTION:

4. Proclamations, Resolutions, Plaques, and Announcements

A. Presentation of a proclamation designating October 3-9, 2021 as "Georgia Cities Week" in the City of College Park. See attached proclamation.

5. Remarks of Citizens
6. Other Business

A. Consideration of an action to honor of the late Jack P. Longino. See memorandum dated September 1, 2021 from Interim City Manager Mercedes Miller.

ACTION:

B. Discussion and update on top ten delinquent property tax payers. See memorandum dated September 1, 2021 from Director of Finance & Accounting Althea Philord-Bradley. Also, see attached background information.

- C. Discussion and update on top ten delinquent utility customer accounts. See memorandum dated September 1, 2021 from the Director of Finance & Accounting Althea Philord-Bradley. Also, see attached background information.
- D. College Park Utility Assistance Grant Program Update. See memorandum dated August 31, 2021 from Director of Finance & Accounting Althea Philord-Bradley. Also, see attached supporting documentation.
- E. Consideration of and action on a request for approval of a College Park Football Spirit parade for Homecoming for the Rams football and cheerleading program on Saturday, October 16, 2021. See memorandum dated September 1, 2021 from Director of Recreation & Cultural Arts Michelle Johnson requesting approval. Also, see attached supporting documentation.

ACTION:

- F. Consideration of and action on a request from Mignon Philpotts of Elysium Event Center for approval to host Mardi Gras Birthday Celebration on Saturday, October 17, 2021 at Elysium Event Center with the use of City streets at Hemphill and Hawthorne Ave. See memorandum dated September 1, 2021 from City Clerk Shavala Moore. Also, see attached City of College Park Special Event Form, Hold Harmless Agreement and Certificate of Insurance. Ward 1.

ACTION:

- 7. Public Hearings
- 8. Bids, Change Order Requests and Contracts

- A. Consideration of and action on bids received to perform construction road work on Sky Train Way and Hospitality Way. See memorandum dated September 1, 2021 from Director of Public Works Melissa Echevarria recommending Mullins Brother Paving as the lowest bidder in the amount of \$219,500 to complete road work construction. Also, see attached supporting documentation. This is a budgeted item. Ward 2.

ACTION:

- B. Consideration of and action on a request for approval to purchase Electric Vehicle Charging Stations for the Global Gateway Arena to add another level of service for customers and clients by providing electric vehicle (EV) charging stations. See memorandum dated September 1, 2021 from Power Director Hugh Richardson recommending approval of the purchase and installation of (2) ChargePoint Level 2 dual stations at a cost of \$17,019.00. Also, see attached supporting documentation. This is a budgeted item.

ACTION:

- C. Consideration of and action on a request for approval of a Memorandum of Understanding between the City of College Park and College Park Elementary authorizing the use of the College Park Recreation Center at 3636 College Street and the City Auditorium as an emergency evacuation facility for College Park Elementary School. See memorandum dated September 1, 2021 from Director of Recreation & Cultural Arts Michelle Johnson recommending approval. Also see attached Memorandum of Understanding.

ACTION:

9. Unfinished (Old) Business

- A. Consideration of an appeal notice regarding the alcoholic beverage violation at 5021 Old National Highway (WRAITH). See memorandum dated August 27, 2021 from City Clerk Shavala Moore and attached supporting documentation.

ACTION:

- B. Consideration of and action on a Homestead Tax Exemption for seniors. See memorandum dated September 1, 2021 from Interim City Manager Mercedes Miller. Also, see attached proposed Resolution No. 2021-19.

ACTION:

10. New Business

- A. Consideration of and action on a request for approval of the installation of an art structure on Main Street (and in the future, other areas within the Main Street Program area). See memorandum dated September 1, 2021 from Director of Economic Development Artie Jones recommending approval. Also, see attached rendering of the artwork.

ACTION:

11. City Attorney's Report
12. City Manager's Report
13. Report of Mayor and Council
14. Executive Session
15. Approval of Executive Session Minutes
16. Adjournment

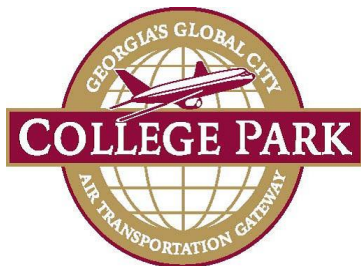

CITY OF COLLEGE PARK

P.O. BOX 87137 · COLLEGE PARK, GA 30337 · 404.767.1537

REG SESSION AGENDA REQUEST

DOC ID: 8993

DATE: August 31, 2021

TO: The Honorable Mayor and Members of City Council

THROUGH: Mercedes Miller, Interim Ciity Manager

FROM: Gabrielle Thornton, Deputy City Clerk

RE: Regular Session Minutes dated August 16, 2021

See attached Regular Session Minutes dated August 16, 2021.

Thank you.

ATTACHMENTS:

- RS081621 (PDF)

Review:

- Gabrielle Thornton Completed 08/31/2021 8:39 AM
- Rosyline Robinson Completed 09/01/2021 12:10 PM
- Mercedes Miller Completed 09/01/2021 10:44 AM
- Mayor & City Council Pending 09/07/2021 7:30 PM

1 CITY OF COLLEGE PARK
 2 MAYOR AND CITY COUNCIL
 3 REGULAR SESSION
 4 AUGUST 16, 2021

5
 6 **MINUTES**
 7

8 Present: Mayor Bianca Motley Broom; Councilmen Ambrose Clay, Derrick Taylor, Ken
 9 Allen, and Roderick Gay; Interim City Manager Mercedes Miller; City Clerk
 10 Shavala Moore; City Attorney Winston Denmark.

11
 12 Absent: None.

13
 14 1. Opening Ceremonies.

15
 16 A. Pledge of allegiance to the flag.

17
 18 B. Invocation by Pastor Alexander.189

19
 20 2. Additions, Deletions, Amendments, Or Changes To The Agenda.

21
 22 Interim City Manager Mercedes Miller said I would like to remove Item 10c from the
 23 agenda.

24
 25 **ACTION:** Councilman Clay moved to remove Item 10c, Consideration of and action on a
 26 Resolution to authorize the College Park Business & Industrial Development
 27 Authority (BIDA) to refinance all of the obligations related to the previously issued
 28 Atlanta Land Purchase Revenue Bonds, Series 2014, seconded by Councilman
 29 Taylor and motion carried. (All Voted Yes).

30
 31 3. Presentation Of Minutes Of City Council.

32
 33 A. Regular Session held August 2, 2021.

34
 35 **ACTION:** Councilman Clay moved to approve Regular Session Minutes dated August 2, 2021,
 36 with corrections, seconded by Councilman Taylor and motion carried as follows:
 37 (All Voted Yes).

38
 39 Packet page 19, line 566 - "...hopper..." s/b "...Hummer..."

40
 41 4. Proclamations, Resolutions, Plaques, And Announcements. None.

42
 43 5. Remarks Of Citizens.

44
 45 City Clerk Shavala Moore went over the rules for public comment.
 46

47 Mayor Motley Broom said there are a number of public hearings. If you are here for the
 48 public hearings, we ask that you reserve your comments at that time.
 49

- 50 a. Ruth Nelson, 4744 Delano Road, College Park, Ga., came forward and said I am not a
 51 resident of the city. I am working in an area of the city. I was trying to find out when
 52 the meetings were happening, how to participate, et cetera. And I found it very difficult
 53 to find this information. We came to City Hall for a Zoom hearing. The agenda was not
 54 posted at City Hall. I went to the information desk to ask the young lady where the
 55 agenda is, and she gave me the number to call The Collaborative Firm. I was getting the
 56 run around. Elderly people in the area, African Americans, who are not confident to use
 57 computers. One lady is very elderly, and we had to try to put her Zoom application on
 58 her phone. I know that COVID has changed things, but we are going to have to change
 59 so that every citizen can participate. There is a big gap that is lapping. I had an elderly
 60 lady that could not sign in, so that needs to be considered before anything is determined.
 61 COVID should not change this that drastically.
 62

- 63 b. (Read by City Clerk via email). My name is Whitney Flemister. I live at 4195 Leesburg
 64 Drive. I want to tell you how pleased I am with the process and development of the
 65 Splash Pad at Phillips Park. And I want to thank Mayor & Council for the continued
 66 support of this project and my vision of new innovative and recreational facilities across
 67 the City of College Park. I would like to especially thank Councilman Roderick Gay for
 68 his tireless efforts in not giving up on the vision that has been put before him. It warms
 69 my heart to know that in these troubling times that we, as a city, can come together and
 70 make history and have things happen within our city. Thank you all. God bless.
 71

72 Mayor Motley Broom asked, is there anyone that wishes to speak for 1 minute?
 73

- 74 c. Mr. Tracey Wyatt, Former Councilman for Ward 3, said I want to come and thank those
 75 individuals and those apartments that showed their love and compassion. I know it has
 76 been a month since my mother has passed, but I haven't had an opportunity to come up
 77 and thank everyone. I thank everyone for all the love that you showed me and my family
 78 during a very difficult time. Those who know me know that me and my mom were super
 79 tight. I just thank you all very much.
 80

- 81 d. Mr. William Walker came forward to speak.
 82

83 Mayor Motley Broom asked Mr. Walker to have a conversation with City Manager
 84 before he speaks.
 85

86 Mr. Walker complied. Thank you.
 87

88 6. Other Business.
 89

- 90 A. COVID-19 Update.
 91

92 Fire Chief Wade Elmore came forward and said there has been changes daily. The numbers
93 that I provided when we put the presentation together has changed. Some numbers may
94 have increased. I do have Division Chief Ron Taylor here who will be providing various
95 phases. If you have any questions, I have our Dr. Robinson here also.
96

97 Fire Chief Wade Elmore said as of last Friday, the State of Georgia had 982,589 cases. And
98 as of today, there are 996,653. The last 3 days from Friday until today, the change was
99 about 14,000 new cases with COVID. That is how fast it is spreading.
100

101 Fire Chief Wade Elmore said Fulton County on Friday, there was 91,459, and today is
102 92,522. There is a difference of 1,063 cases in Fulton County alone. Hospitalizations in
103 Fulton County on Friday were 5,718; and today is 5,727. This graph that I am showing you
104 is a graph from when COVID started back in January of 2020 until today. If you look over
105 to your right, the arrow that is going up, the trend is going back up drastically, and that is
106 what we are trying to keep an eye on.
107

108 Fire Chief Wade Elmore said in the State of Georgia, there are 4,136,214,000.00 fully
109 vaccinated individuals. Of that number, 4,908 have tested positive. And of that 4 million
110 there are 118 hospitalizations and only 24 deaths. This graph shows you that vaccinations
111 do work. It slows it down, but it is working. That is why we urge everyone to get
112 vaccinated, if possible.
113

114 Fire Chief Wade Elmore said IT has installed temperature scanners in City Hall. This gives
115 us a number of various people that comes in, and they may have a temperature of 100.4. If
116 they have a temperature of 100.4, we are not letting them in public facilities. And we did
117 notice that because we have been having some very hot days, people are walking to the rec
118 center, and when they enter, if their temperature is above 100.4, we try to wait a few minutes
119 until their body temperature cools down. Some may reenter and their temperature is normal.
120 We do have a number of people trying to enter with higher body temperatures.
121

122 Fire Chief Wade Elmore said for employees, we have confirmed positive cases. We have 7
123 individuals that have tested positive for COVID. We do have the various departments. You
124 can see the number of employees who have tested positive. Like I said, that is 7. And we
125 only have 2 that have been exhibiting symptoms, and that is 2 of that 7. On Friday, we had
126 5 firefighters who answered a call on a COVID patient, and we had to send them home until
127 they get tested. We will give them 3 to 4 days before they get tested, and they should be
128 getting their results back in the next few days.
129

130 Fire Chief Wade Elmore said so total cases, 12 within the city employees. We have a total
131 of 88 that have recovered, and that is over the last 16 to 17 months. And we have 213
132 employees that are vaccinated, and 129 employees who have not been vaccinated as of
133 today.
134

135 Fire Chief Wade Elmore said we have recommended, and we are doing this in most of our
136 facilities, wearing a mask in common areas within all of College Park facilities, daily

137 cleaning and disinfecting in all of College Park facilities. And we are beginning to
138 implement closure phases, if the numbers continue to increase.

139
140 Division Chief Ron Taylor said good evening Mayor & Council. Emergency Operation
141 Teams have proactively brought before you 3 different phases, which we will need to move
142 on, based on the number of cases rising. Phase 1 will include 50 percent staffing and 50
143 percent remote and limited meetings within the City buildings. Phase II would be 80
144 percent remote and 20 percent in-house and suspension of all in-house meetings. Phase III
145 would be only essential personnel; i.e., police, fire, public works, and IT.

146
147 Division Chief Ron Taylor said we are basing our action plans on the possibility that this
148 COVID virus, along with the Delta Variant, will repeat what happened in January of last
149 year. So, we are recommending that Mayor & Council immediately activate Phase I of our
150 remote operations. By November of this year, if the numbers continue to climb, and the
151 trend continue to go upward, we will implement Phase II. If the trend continues to repeat
152 itself as it did last year with a peak right in the middle of the year, we move into Phase III of
153 our remote operations. Questions?

154
155 Councilman Allen said your recommendations, they could speed up or slow down
156 depending on the number of cases.

157
158 Division Chief Ron Taylor said yes, sir. The recommendation is to proceed with Phase I
159 based on the numbers trending. And history has shown that the peaks dramatically will go
160 up. We want to be ahead as opposed to the middle or behind. We want to be proactive
161 making sure that employees are safe and that College Park and the citizens are still
162 receiving services, even though we are reacting to this trend.

163
164 Councilman Allen said November for Phase II. If the cases continue to go up, that could
165 come earlier.

166
167 Division Chief Ron Taylor said yes, based on the data we have already had.

168
169 Councilman Gay said my only thought is that it is not consistent because you have school
170 kids at school based on a different ratio versus student population. And then you have
171 family members that are going to work. So, it is just not consistent for me. We need to find
172 a way to be consistent with other organizations. I can't make sense of it.

173
174 Mayor Motley Broom said the latest numbers we had was 512 cases. So, we are seeing
175 some really significant increases, especially per capita that are deeply concerning, and the
176 CDC has their threshold at 100 per 100,000 people. So, the steps that we are speaking of
177 operationally, we can stop that infection rate within the city. It certainly makes sense to
178 move to Phase I.

179
180 Mayor Motley Broom asked, any other questions?
181

182 Councilman Taylor asked, so what do we start back doing? I think we should have started
183 yesterday.

184
185 Interim City Manager Mercedes Miller said beginning tomorrow, Phase I.

186
187 Mayor Motley Broom said thank you gentlemen. I appreciate your time and all the work
188 you put into it.

189
190 B. Discussion and update on top ten delinquent property taxpayers.

191
192 Mayor Motley Broom asked, any questions for Ms. Philord-Bradley on 6b and 6c?

193
194 There were no questions made.

195
196 C. Discussion and update on top ten delinquent utility customer accounts.

197
198 There were no questions on this item.

199
200 D. College Park Utility Assistance Grant Program Update.

201
202 Mayor Motley Broom asked, any questions anyone has on this item?

203
204 Director of Finance & Accounting Althea Philord-Bradley said I don't have any news to
205 share, so I will take any questions the Council may have.

206
207 Mayor Motley Broom said it doesn't look like the numbers moved up. Are you still
208 accepting applications?

209
210 Director of Finance & Accounting Althea Philord-Bradley said yes, ma'am, until the money
211 runs out.

212
213 Councilman Clay said we've only spent half the money, correct?

214
215 Director of Finance & Accounting Althea Philord-Bradley said yes.

216
217 Councilman Clay said if you feel you are qualified for the program, you should do it.

218
219 Director of Finance & Accounting Althea Philord-Bradley said we are catching those on the
220 disconnected list and giving them an opportunity to apply as well.

221
222 Councilman Clay said I noticed you have a certain number of people to come in, sign up, and
223 address things, and they don't show up. Do they ever show up?

224
225 Director of Finance & Accounting Althea Philord-Bradley said I'm not sure. I will have to
226 get with the Grants Coordinator to see what the ratio is.

227

228 Mayor Motley Broom asked, any other questions for Ms. Philord-Bradley?

229

230 There were no other questions.

231

232 7. Public Hearings.

233

234 A. Public Hearing to consider an ordinance regulating container style buildings within the
235 City Of College Park.

236

237 City Planner Nikki Washington came forward and said this is the same ordinance we talked
238 about a couple of weeks ago. I did get a couple of comments from Councilman Clay. The
239 only thing I think was left unresolved was the color palette recommended by the Planning
240 Commission. We don't have a color palette in the city. So, I went with one that is
241 compatible that is used within the district.

242

243 Councilman Clay said that is what I thought you were doing. This is a public hearing.

244

245 Mayor Motley Broom asked, any questions for Ms. Washington?

246

247 There were no questions.

248

249 Councilman Allen said you have done a good job looking at it.

250

251 Mayor Motley Broom declared the public hearing open.

252

253 Mayor Motley Broom asked if there was anyone from the public that would like to speak for
254 or against an ordinance regulating container style buildings.

255

256 There were no comments from the public.

257

258 Mayor Motley Broom declared the public hearing closed.

259

260 Mayor Motley Broom called for a motion.

261

262 **ACTION:** Councilman Clay moved to approve a request from City Planner Nikki Washington
263 for an ordinance regulating container style buildings within the City of College
264 Park, seconded by Councilman Taylor and motion carried. (All Voted Yes).

265

266 B. Public Hearing to consider transmitting the draft City of College Park 2021
267 Comprehensive Plan update to Georgia Department of Community Affairs (DCA) for
268 review.

269

270 City Planner Nikki Washington said ARC is here to give a quick presentation on our
271 Comprehensive Plan process for the public. This is all stuff we have seen before, but just a
272 quick reminder of what we are doing. And if you have any questions for me, I can take those.

273

274 Ms. Anna Beckett, Senior Planner with ARC, came forward and gave a power point
 275 presentation. At the original public hearing, we went through the general requirements and a
 276 general overview of where we are with the plan. I will skip to the last slide to document our
 277 progress.

278
 279 Ms. Beckett discussed the schedule overview. If you decide to move forward with the
 280 transmittal, we will submit to the DCA and the ARC for review. There are still opportunities
 281 to edit the plan and provide additional comments. If you do decide to transmit the document,
 282 there cannot be wholesale changes to required elements that DCA requires, and there cannot
 283 be wholesale deletions either. The deadline for submittal is October 31, 2021. Right now we
 284 are on track with that. I will pause there and let you ask any questions you may have.

285
 286 Mayor Motley Broom asked, any questions?

287
 288 Councilman Allen said thank you for the job you have done. I thought it was a great
 289 document.

290
 291 Mayor Motley Broom said there were a couple of typos throughout.

292
 293 Councilman Clay said well done. I got all my questions answered.

294
 295 Ms. Beckett said thank you for serving on the steering committee Councilman Clay.

296
 297 Mayor Motley Broom declared the public hearing open.

298
 299 Mayor Motley Broom asked if there was anyone from the public that would like to speak for
 300 or against transmitting the Draft of the Comprehensive Plan to the Department of
 301 Community Affairs for review.

302
 303 There were no comments from the public.

304
 305 Mayor Motley Broom declared the public hearing closed.

306
 307 Mayor Motley Broom called for a motion.

308
 309 **ACTION:** Councilman Allen moved to approve a request from City Planner Nikki
 310 Washington to transmit the draft City of College Park 2021 Comprehensive Plan
 311 update to Georgia Department of Community Affairs (DCA) for review, seconded
 312 by Councilman Clay and motion carried. (All Voted Yes).

313
 314 C. Public Hearing to consider the rezoning of 0 Welcome All Road from BP - Business
 315 Park to M1 - Light Industrial Zoning District. Ward 2.

316
 317 City Planner Nikki Washington came forward and said I know we have a lot of people who
 318 wish to speak and get answers on this. We did have 1 recommendation from Councilman
 319 Clay that I would like to add to the recommendations, noise mitigation (reading). At least 65

320 dB as a condition on No. 9, and I have a resolution if Council agrees. I will update that as
321 well.

322
323 City Planner Nikki Washington said we want to change the distance from any storage
324 container from 100 feet to 115 feet.

325
326 Councilman Clay said I said that because that was originally in the Planning Commission's
327 recommendation, I believe. And the next bunch was in Condition 3, which is the screen to be
328 effective year around. If you have enough trees, even if the leaves are off, it is going to block
329 the view from the residents. But if you don't have enough trees, then you may need to add
330 some non-deciduous trees that will block those all year around.

331
332 City Planner Nikki Washington said yes.

333
334 City Planner Nikki Washington said this is an application for the battery storage facility.
335 The applicant is here, and they have a short video they want to present. It was in your
336 packet. We would like to show that video to introduce everybody to the project.

337
338 **(Video played by Nextera Energy)**

339
340 Mr. Harold Buckley came forward on behalf of Nextera. We have seen the staff report with
341 the conditions. We haven't seen all the changes. But we are okay with the increase from 100
342 feet to 115 feet. And the noise condition, we would ask for a minor modification. At the low
343 end, we would expect our equipment to be at 61 dB(C). so I just wanted to make sure that this
344 fell within the range that Councilman Clay recommended for the rezoning condition. If so,
345 that is fine. And rather than take up a lot of time, I will reserve the rest of my time for rebuttal,
346 and that way I can be more on target and relevant.

347
348 Councilman Clay said we have had conversations, and the low frequency response you said
349 was 61 dB(C), and that would be 24 hours a day.

350
351 Mr. Buckley said we understand that there are sound limits that are present in your Code, but
352 we are presently in dB(A) and not dB(C). So, what our sound engineer did over the weekend
353 was to convert the dB(A) limits to dB(C) limits. And we understand dB(A) is 60 and that
354 converts to 74 on dB(C). And the nighttime limitation is 50 dB(A) which we understand is
355 64 dB(C).

356
357 Councilman Clay said that does not quite agree with what I told Nikki, but 60 and 50 is what
358 is in the ordinance, and I was quoting from a different part of the ordinance. I was using some
359 FDA guideline, but 60 and 50 is what we have in there. And at 50 dB(A), the dB(C) scale is
360 about 30 dB higher or so. 60 and 50 are pretty reasonable, I think.

361
362 Mr. Buckley said okay.

363
364 Councilman Allen asked, so it's a different calculation for night and day?
365

366 Mr. Buckley said your code allows a somewhat higher noise level in the daytime that it does
367 at night.

368
369 Councilman Clay asked, did you identify the frequencies when you had your noise analyst
370 in? What I don't have data on is what are the frequencies that are loudest in the sound
371 distribution from your equipment? I consulted a MEAG engineer, and they said 60Hertz
372 and 180Hertz were the predominant noises from, for example, transformer equipment.
373 What I don't know is what is the noise level from your inverters? Because they don't operate
374 at 60Hertz, they probably operate as 14 kilohertz, I don't know. Another thing is fans. Are
375 there cooling fans in the equipment?

376
377 Mr. Buckley said I have a number of consultants with me because I'm not nearly smart enough
378 to answer all your questions, so if I may call Rashanna B ??? (sp) to speak to operational
379 questions like that.

380
381 Councilman Clay said my biggest concern for the residents is primarily noise, which may
382 not be what they think they're concerned about.

383
384 Ms. Rachana Vidhi said the technology that we typically would apply would have industrial
385 HVAC units, or it would have a liquid cooling system, which would require a chiller. So, the
386 technology that we have are air currents or a digital cooling system which would require a
387 chiller. Matt Towery (Nextera) is here, and he is my colleague and the engineer for the
388 project.

389
390 Councilman Clay said it is not noise from the transformers, it is not noise from the inverters,
391 it is primarily noise from the air-conditioning.

392
393 Ms. Vidhi said that's correct.

394
395 Councilman Clay asked, is that noise from the air-conditioning from compressors or is it from
396 fans?

397
398 Ms. Vidhi said I believe it will be the fans, but I'm not sure.

399
400 Mr. Towery said correct, yes.

401
402 Councilman Clay said we have a large installation that is a blockchain processing
403 computing system that I just took noise measurements on. The one fan system was fans
404 running on the back of small computing processor units generated frequencies that were very
405 audible; 2 kilohertz, 1 kilohertz, et cetera. When they put in the large ventilation fans and
406 eliminated the small fans, the frequency dropped considerably, more like 800Hertz to
407 1,000Hertz. So, it lowered it in frequency. So, I'm just trying to get a feeling because the
408 equipment may change.

409

410 Mr. Towery said we could go back to the noise study we did to look at those values. The
411 containers may be using liquid cooling. Your transformers that are on your substation
412 would have a lower hertz than your battery containers. We can go back and pull some data.
413

414 Councilman Clay said all we want to do is to make sure that we don't have a continuum, and
415 we know when the batteries charge up, you are going to get one set of noise. When the
416 batteries discharge, you may get a slightly different frequency on noise. So, that's why we
417 try to set limits at the boundary of the facility, and the spectrum is of interest simply because
418 of how it is going to propagate.
419

420 Councilman Clay said my concern is that if you don't meet the requirements at the
421 boundary, then we are going to have to do something about it, and that would be some kind
422 of a noise barrier installation. We already have one that we have planned for at this
423 computing facility in the city. And as I see it, that would only be necessary to be done in
424 areas where it actually bordered residential property. I think there are some apartments that
425 are affected, and some homes are nearby the facility. But the large amount of your
426 periphery there does not have residential next to it. So, it would only be in those areas
427 where we actually had people living on the other side of it. And my biggest concern was the
428 low frequency noise. But the more I thought about it, your air-conditioning noise would be
429 perhaps louder than the transformers. People cannot hear 60 cycle hum very well, although
430 you can feel the vibration if you are close to it.
431

432 Councilman Clay said I think if 60 and 50 dB(A) converted to dB(C) is probably a good
433 measure. DB(C) is a flatter measure as you know and she knows at least, and that takes
434 account of the low frequency, as well as it does the higher frequency. So, I like the fact that
435 you converted it to dB(C).
436

437 Councilman Gay said I have 3 comments. Are these lithium-ion batteries that you will be
438 storing?
439

440 Mr. Towery said that is the current trend. The chemistry could potentially change.
441

442 Ms. Vidhi said most likely there are going to be installing lithium-ion batteries. And with
443 lithium-ion batteries there are a lot of sub-chemistries which are specific types. And that is
444 where the industry in general is not sure exactly where it will go. But we are going to work
445 with suppliers who have proven that they have the technology and are backable.
446

447 Councilman Gay said when they are packed tight together, they have been known to cause
448 sparks, explosions. Are we trained for that? And the second one that is as important as
449 noise would be ventilation, and firefighters need to be trained to deal with that.
450

451 Mr. Buckley said with regard to fire and combustion risk, we have Paul Hayes with us. He
452 is our fire consultant, and he can speak directly to that for you.
453

454 Mr. Paul Hayes, American Fire Technology, came forward and said I have been specialized
455 as a battery expert to a number of jurisdictions in the country, including New York City. I

456 manage the rewriting of the code for vibrations, suppression, and about a 150-page
457 lithium-ion guide. Gases do come off batteries in failure mode. The most important piece
458 of equipment in this system is a battery management system. We do modeling. We do look
459 at the gas productions and how they can be managed.

460
461 Mr. Hayes said fire is not as great a risk as the vibrations. One of the first things we did
462 was we went to the fire department and said this project is coming. Ask me any questions
463 you would like to know, and I will tell you what the country is doing, what our best
464 practices are, and we will bring those to bear on this project, and we will educate you and
465 make sure that you are comfortable with any hazard that you may find in the field from any
466 failure.

467
468 Mayor Motley Broom asked, is that something that you have done with our Fire Department
469 as well?

470
471 Mr. Hayes said yes. We have approached both.

472
473 Councilman Clay said there is a requirement in this approval tonight that the Fire
474 Departments be trained, both South Fulton and College Park, be trained on how to suppress
475 these fires.

476
477 Mr. Hayes said water is not bad, but it is used mostly for heat mitigation. When I go into a
478 fire department I say do not jeopardize life and safety for an asset. But you may sit back and
479 make sure that that heat transfer is managed. And we do those evaluations on heat transfer
480 and problem propagation. Propagation is external to a battery. We can't stop the thermal
481 runaway on a failure, but we want to manage the propagation, so we can limit the
482 propagation, and then that will keep the system from continuing to cycle.

483
484 Councilman Clay said there is another requirement in there that there not be combustible
485 material. Our Fire Department has looked at this as well. There has to be a certain number
486 of feet apart, et cetera, et cetera. So, there is a lot. But I take it that your battery management
487 system should automatically shut down a module, if there is a problem, And you have a
488 remote alert system to shut it down remotely. So, if there is a failure in a cell, and it starts to
489 propagate, you can shut down the draw on all the other cells in that module.

490
491 Mr. Hayes said correct.

492
493 Councilman Gay said on the grid, this is more of a product that you want to bring. It's not
494 reducing our daytime outage that is making any benefit to us, correct?

495
496 Mr. Hayes said I'm the safety guy, so I would have to defer that question on what the
497 capabilities are.

498
499 Councilman Allen asked Chief Elmore, how do you feel as far as safety equipment, training,
500 and so forth?

501

502 Fire Chief Wade Elmore said we have met with them a few times, and I'm comfortable with
503 it. My only concern was the location. But other than that, as far as fire extinguishment, I
504 think each container will consist of its own extinguishing system.
505

506 Councilman Allen asked, have you talked with South Fulton at all?
507

508 Fire Chief Wade Elmore said we have.
509

510 Councilman Allen asked, and they will receive the training and equipment?
511

512 Fire Chief Wade Elmore said correct.
513

514 Mr. Hayes said I am available for them, if they have any questions. You have a question on
515 ventilation.
516

517 Councilman Gay said ventilation, and what impact does it have on our grid?
518

519 Mr. Hayes said I will pass on the grid question. But on the ventilation, we do some modeling.
520 We look at multi-levels of failure so that we have a good understanding of what levels we will
521 be able to maintain, if we have a single cell and what that gas production looks like. We do
522 large scale fire testing within UL that is all within the code, so we can put some safety margins
523 on what that test tells us, how much gas is produced on a single cell so we start looking at
524 failure modes that would be able to mitigate larger events if necessary, and we design that
525 mitigation for gas detection.
526

527 Mr. Buckley said Mr. Young is our project manager, and he can speak to the benefits of the
528 project for College Park.
529

530 Mr. Young said I am at 700 University Boulevard. This project is about resiliency of the
531 transmission grid. It allows a potential customer to store their energy in these batteries and
532 be able to use it when it is most needed. It is storing or increasing the reliability of the
533 transmission grid, and we would market the project to a potential customer, someone that
534 has access to the Georgia integrated system. As far as the other benefits from the project,
535 it's a tax revenue story. You are looking at \$60 million in tax revenues that benefit the
536 citizens of College Park. And the way we do it is that \$60 million from tax revenue doesn't
537 create additional strain on the resources that College Park has. And there is no traffic flow to
538 the site, other than 2 or 3 people that are going to the site. It will create a significant amount
539 of jobs during the construction period. I would be happy to address any questions you have
540 on the benefits. I hope I summarized that for you.
541

542 Mr. Hayes said yes.
543

544 Councilman Gay asked, the \$60 million proposed tax revenue, that is if we get a buyer,
545 correct?
546

547 Mr. Young said we would market to Georgia customers that would see the benefit having
548 the energy when needed and having a different form of generation standing by.

549
550 Councilman Clay said there are times when College Park has to buy power off of the spot
551 market. That spot market is the market that is being fed by generation plants. And it
552 also is being fed by the battery generation plants, if you will. And it should lower the cost
553 for everybody buying power on the spot market.

554
555 Mr. Young said to increase reliability and the damages and the economic benefits to it.

556
557 Mayor Motley Broom asked, has Nextera, have you presented this to any of the IT people
558 yet?

559
560 Mr. Young said yes.

561
562 Mayor Motley Broom asked, to whom?

563
564 Mr. Young said there are certain confidential requirements within those proposals that we
565 have complete confidentiality while we are actively bidding with them.

566
567 Mayor Motley Broom said there are 4. I could probably call MEAG now, and my guess is
568 no.

569
570 Councilman Allen asked, can you go over noise buffers with me, the buffers around the
571 perimeter.

572
573 Mr. Young said at a minimum of 15 foot active buffer on the facility. There are many areas
574 on the facility that are vegetative buffers. The maps show how far the project is from the
575 residents.

576
577 Councilman Clay said if it doesn't shield, you guys will add vegetation that does shield.

578
579 Mr. Young said we are completely comfortable with that.

580
581 Councilman Clay said as far as we are concerned, the noise requirements are at the
582 boundary. So, if that boundary is separated by 15 feet of vegetation, it is not your site of the
583 vegetation, it is at the boundary that is close to the residents. And if you don't meet that,
584 that is where we want you to put it on your side of the vegetation, so the residents don't have
585 to look at a wall. Our requirements in our ordinance is that it be met at 5 feet measurement
586 above the ground, et cetera, et cetera. Those are the kinds of things that we are talking
587 about. And it is also effective at lower frequencies. However, it seems to be like we also
588 have higher frequency to contend with, and that will block the higher frequency.

589
590 Mayor Motley Broom asked, any other questions?

591
592 There were no other questions from the Body.

593 Mayor Motley Broom declared the public hearing open.

594

595 Mayor Motley Broom asked if there was anyone from the public that would like to speak for
596 or against the rezoning of 0 Welcome All Road from BP to MI Zoning.

597

598 Mr. Joe Stalls, 605 Escalade Drive, came forward and said I live in the Sunrise
599 neighborhood next to the proposed facility. When I came here tonight I was apprehensive
600 and didn't know what was going to happen. Right now I am terrified. They don't know
601 what is going to happen with these batteries. How in the world? We are not talking about
602 noise if something happened, and we don't know if these batteries have cancer. I am
603 looking at my kids and grandkids growing up. What is our property going to be like? This
604 could be another Erin Brockovich situation. You asking them and they don't know. This is
605 our lives. No money is worth a life. And we don't know if they are putting something over
606 there to kill all of us. I implore you to vote no for this. They can go to rural Georgia or
607 somewhere else. I know you need revenue, but let a developer put an office park or housing
608 or something else in that area that won't be a detriment or won't put our lives at risk. What
609 about if the batteries catch on fire, and they have to put it out, and that stuff runs in the
610 creeks behind our houses? So, please don't let it put our lives in danger.

611

612 Mr. Jonathan Smith, 4680 Delano Road, College Park, Ga., came forward and said I am a
613 resident of Atlanta Road. I want to thank everyone for coming out to speak on behalf of
614 this item. At this point, we are being put off as an asset. They said we don't risk a life to
615 save an asset. We are not assets, we are residents there. They are building this at the end of
616 our street. I have dogs. So, it might be something that my dog can hear and that puts our
617 pets in danger. And when it comes down to lithium ion batteries, do you remember the
618 old Samsung cell phones that were catching on fire and exploding? If you overcharge it, it
619 would catch on fire. We are risking ourselves because we have a lot of times when power is
620 out, and there is no one there to shut it down or anything of that nature, or batteries
621 overcharge. You can't use water. So, that is taking money out of the taxpayer dollars to get
622 something to extinguish that. And a lot of our residents are elderly. Because of COVID,
623 people cannot come to the meetings. Some people in my family can't even check email.
624 We are being forced to be stuck with something that does not benefit us for a mutual gain
625 for someone that doesn't even care about us at this point. We are labeled as assets instead of
626 residents. We have been there for generations. I hope you vote no on this.

627

628 Ms. Tonya Brown, 363 Bradford Cove, College Park, Ga., came forward and said my
629 mother lives in the area, and she is just a couple of miles away from where the project is.
630 And we all have the same concerns. The main concern is the safety issue that is around this
631 building proposal. So, we are asking and begging that you please put yourselves in our
632 shoes. We all have family members, children, and some people haven't even had their
633 babies there. Just vote no on this.

634

635 Ms. Talani Alex, 4744 Delano Road, College Park, Ga., came forward and said when they
636 first started this zoning or whatever, none of the community was notified. On Atlanta Road
637 you can't see the sign because grass was covering it. They didn't tell anyone. Welcome All
638 Road is in a curve, so if you tried to see the sign you would run off the street. They had a

639 Zoom meeting where the elderly doesn't know how to get on Zoom. And we are just very
640 upset about that because no one told us about it. We were not notified until the last minute.
641 It was just poor how they tried to present it out to us. Thank you.
642

643 Mr. Paul Loveless, 4140 Jeffrey Drive, College Park, Ga., came forward and stated his
644 concerns about the lithium batteries. That parcel ID is posted on the sign when we first
645 heard about it. That parcel ID is not mentioned in the 3 parcels ID's that was mentioned on
646 the attorney's letter to you guys. Those parcel ID's are also listed as agriculture from the
647 Fulton County Tax Assessor's Office. They are not listed Business Park. So in essence,
648 they can't ask you guys to go from agriculture to M1. Agriculture is not a land use. I am
649 asking Council to please vote no on this situation. Because like so many others, these
650 chemicals are toxic to the breathing itself. We are talking about a serious untested adventure
651 in the backyard of these people. The signs were sideways. So, we need substantial process.
652 We need you to step back from this. We need you to deny it. If you don't deny it, please
653 delay this until we can get a solid design, solid chemistry, and science on this situation. It
654 doesn't even show business on your land use plan. It is the future land use for commercial
655 and business park. We believe that when a project comes into the community, we are
656 neighbors. What if we run a campaign to boycott College Park? How would it feel? That is
657 how it feels to us. Is this a Florida company? It is obvious that they are not set to benefit
658 us, and it will be in our backyards around the people that are not able to even come out and
659 speak at these meetings. I do thank you for your time tonight. I want to put those points
660 into the record, as well as to ask you all to reconsider the hearing for input. The citizens
661 cannot participate. They were not notified. Thank you.
662

663 Mr. Lexington High, 4700 Delano Road, College Park, Ga., came forward and said there is
664 lack of information surrounding this parcel. It was pretty slim information, and that
665 information provided much for now. There was a meeting on June 28, 2021, and at the
666 Planning Commission meeting they added conditions to the motion to get out an
667 informational to the residents of South Fulton and some with College Park about the project
668 before they submitted this up for a vote. And I never received a follow up after that. They
669 were aware that citizens were not property notified. That was the wrong parcel or the initial
670 invite, and no one followed up with us on it. Nextera and the City of College Park will have
671 the City of South Fulton that is affected by this. They have their best interest in mind.
672 Going forward, I would like to see information where Nextera has done something similar in
673 neighborhoods, and how those residents feel about Nextera and these types of undertakings.
674 That's all I have.
675

676 Mayor Motley Broom said thank you, sir.
677

678 Councilman Allen said thank you.
679

680 Ms. Shelvie High, 4744 Delano Road, College Park, Ga., came forward and said I own
681 several properties on Delano Road. Councilman Clay, do you know how many batteries
682 they are talking about storing on that facility?
683

684 Councilman Clay said it's a very large number.

685 Ms. High said you have to multiply it by that very large number, don't you?
686

687 Councilman Clay said it doesn't quite multiply. You have to consider the distance between
688 the source and where you are listing them. Some of them are further away. There is foliage
689 in the middle. The noise will reflect off the devices in the middle. A noise engineer would
690 have to answer that, but I am obviously concerned about that issue.
691

692 Ms. High said the people in my community did not get any money for the noise abatement.
693 There is a quarry, and it shakes our house. The cooling of these batteries and the vibration
694 can make those batteries unstable. They have this barrier of trees that is supposed to be
695 protecting the noise, but what does a tree do if it is lightning? How do you think wild
696 fires start? And this is a heavily wooded area.
697

698 Councilman Clay said I actually drove down to your area.
699

700 Ms. High said those are some of the things that I wanted you to consider. And they say it
701 won't affect us. I have grandkids. So, how can those children rest? They are already in a
702 situation because of the pandemic. And they were born into the world with silence, and now
703 they are transitioning into a hum with noise about the size of a vacuum cleaner. That hum
704 that is in those devices I think will run into our yards and our cars. It is not fair to us as
705 taxpayers. I would also like to invite each and every one of you to Google what happens
706 when the lithium battery discharges. When we initially started this process, we had one
707 parcel number. I have lived in Red Oak for over 50 years. It is zoned agriculture. I tried to
708 purchase it myself. We had a park that was donated to us by Mr. Lee. They would never be
709 able to build anything in that floodplain. South Fulton and Bill Edwards wanted to put the
710 fire station in the floodplain. This whole project should never have happened, and I am
711 hoping and praying and asking that y'all don't let it happen. We have a hole in our street
712 that has been there for 27 days. I almost got hit by a school bus today. Do you think if
713 those batteries caught on fire that College Park would get there in time or South Fulton
714 would try to come on that dead end street and rescue us? And if they could rescue us, where
715 would they take us? I am asking that you find it in your heart to say no to this project. I just
716 feel like since we are one of the older communities that we should have some type of
717 community empowerment. My community needs protection. I am considering running for
718 Mayor. Save our lives.
719

720 Mayor Motley Broom said thank you.
721

722 Councilman Allen said thank you very much.
723

724 Mr. Bill McCrary, 4885 Brooks Drive, College Park, Ga., came forward and said I live off
725 Delano Road. Delano Road is one way in and one way out. The proposed site is right after
726 the entrance to the area. And I'd like to let the Council know that if something were to
727 happen there, no one would be able to get out to Roosevelt Highway because of that
728 situation there. And I want to know if they will consider that, number one. And there is a
729 power line and gas line that runs through there. A 36 inch gas line will be on that proposed
730 site also. I would like for you to consider to vote no for this project.

731 Mr. Jonathan Smith, 4680 Delano Road, College Park, Ga., continued to say I am a resident
732 of Red Oak. Our street actually is a dead end. If anything was to happen, we would be
733 literally stuck because we are at the bottom of the street. We would have no way out. This
734 is our health and our property. That's all I want to add.

735
736 Mayor Motley Broom asked, is there anyone else in the audience that wishes to speak?
737

738 There were no further comments from the audience.
739

740 Ms. Davis (Read by City Clerk via email) said if the City of College Park wants to allow
741 the zoning change, I am a concerned citizen. I was a listener when South Fulton voiced
742 their concerns against it. There were a few on the call, but they were united in opposition
743 and fear. The motion was made to approve the rezoning and the conditions that our City
744 Officials stay in close contact with the City of South Fulton and residents to make sure
745 everyone's needs and concerns are heard. I hope and pray that you keep the community and
746 the residents of South Fulton, and not just the City of South Fulton, in mind and the
747 detrimental changes to the industrial business goals. We have an opportunity to show them
748 otherwise by turning away the large conglomerates. Thank you for your time.
749

750 Mayor Motley Broom declared the public hearing closed.
751

752 Mayor Motley Broom asked, any comments from Council?
753

754 Councilman Clay said I have several questions coming out of this. One is for Nikki. The
755 parcel - - and this is probably the second or third time I've heard about this - - The parcel
756 that was ostensibly zoned as farmland or agriculture, are we talking about parcels that are
757 zoned the way we think they are zoned?
758

759 City Planner Nikki Washington said the parcel in question is DB Business Park that was
760 annexed in 2015 and was zoned into that from then Fulton County. They were part of
761 unincorporated Fulton County.
762

763 Councilman Clay said I may recollect that they were agriculture and they stayed agriculture
764 for like a year or 2 after the annexation, and I believe we changed it. That's my
765 recollection. So, that might explain what was, so we then zoned them at that time Business
766 Park.
767

768 City Planner Nikki Washington said correct.
769

770 Councilman Clay said so Fulton County has not updated their records, probably.
771

772 City Planner Nikki Washington said they have not. There is also the parcel issue. These
773 parcels were combined into that one parcel in the Fulton County map. It's a discrepancy in
774 the parcel, I believe.
775

776 Councilman Clay asked Fire Chief Elmore, should a plan be looked at considering what
777 some of the citizens brought up with regard to one way in and one way out, as far as the
778 disaster plan?
779

780 Fire Chief Wade Elmore said that was the first fire station I worked at. Delano Road is a
781 dead end as they said. And I think they should have another entrance or just another plan.
782 Because like the gentleman and lady stated, that if anything happened, they are blocked on
783 Delano Road.
784

785 Councilman Clay said in all fairness, we have to remember that if this project were to go,
786 sooner or later something else is going to go in there, and it could be in many ways less
787 desirable than this. And it also could be as much of a fire hazard.
788

789 Fire Chief Wade Elmore said we looked at 5 other locations where they had some locations
790 in Texas, Florida, and all their locations were in remote areas and not in neighborhoods.
791

792 Mayor Motley Broom said there will be no comments from the gallery.
793

794 Councilman Clay said thank you Chief.
795

796 Mayor Motley Broom asked, any other questions from Council?
797

798 Councilman Clay said I have a comment. One of the things that has been brought here that
799 concerns me is the vibration issue. If they have blasts going on in the quarry and having
800 truck traffic in that area, should we be looking at the impact of the vibration or should we be
801 making a request to Nextera with regard to whether those battery modules will be shock
802 mounted that could be subject to vibration from blasting and from traffic? I went down to
803 the neighborhood and I measured the aircraft noise on sunrise when planes were flying the
804 244 heading that goes over that area. The decibel level was 75 dB(A). And heading off the
805 runway going west, they were about 65 dB(A). You are going to get vibration from that as
806 well. That is something we might want to look into. And perhaps Nextera has looked into
807 it, so I will address the question to Nextera. What is your response to that? Lithium-ion
808 batteries are subject to damage from vibration. You shock mount the structures, the
809 containers, or you design the battery racks inside the container so that the vibration is not
810 transmitted to the batteries. And that is something that you may not have encountered at other
811 locations.
812

813 Mr. Hayes said it's a good question. I have not come across vibration. But what I will say is
814 that part of the mitigation strategies in the code requires you to do a hazard mitigation analysis
815 that looks at things like hard flash certifications. There is a UL Listing 9540 that is required
816 for the systems to be put in operation. It requires those system requirements to be vetted. And
817 we put that into a fire risk assessment, and we look at all the potential failure pathways and
818 put them into a comprehensive report and submit it to the fire marshal for approval.
819

820 Councilman Clay said to summarize what you just said, we should make a requirement, if
821 we approve this, that the Fire Chief has to sign-off on the battery technology that is

822 employed and is subject to review whenever that technology is changed. Does that make
823 sense to you Chief?

824
825 Fire Chief Wade Elmore said yes, sir.

826
827 Councilman Clay said we need to say in the approval that that review has to be in there. Do
828 you have that in there Chief?

829
830 Fire Chief Wade Elmore said I don't know.

831
832 Councilman Clay said the technology should be approved by the Fire Chief.

833
834 Councilman Clay said one good piece of news from what I have been reading technology
835 wise, there is a new ion technology that they are looking at that isn't useful for things that
836 move like aircraft or vehicles, but for things that are in place, fixed location, because it is
837 heavier, but it is much safer from a fire standpoint from what I understand; is that correct?

838
839 Ms. Vidhi said the ion technology that has just came out is so new. It is good for seasonal
840 storage. So, you would potentially charge the battery over a few months and then discharge
841 for a few months.

842
843 Councilman Clay said that is why we need the Fire Chief to certify that it is acceptable.

844
845 Mayor Motley Broom asked Mr. Buckley to describe the outreach that Nextera did for the
846 residents surrounding this proposed project.

847
848 Mr. Buckley said in my hand are the certified receipts for all the individual notices that we
849 made to the neighbors in the area. We got the mailing list for these notices from your planning
850 staff. This was an issue that was raised at the Planning Commission hearing, the sufficiency
851 of the written notice that was mailed and the signs posted. And the planning staff confirmed
852 that the public notice was done correctly.

853
854 Mr. Buckley said what we did for the public notice was we sent the required public notice that
855 the City requires to you to send that described the zoning application, and it gives the planning
856 staff's contact information if anyone has any questions. When it came up at the Planning
857 Commission Meeting that some people were apparently not getting out mailings, it might be
858 because these mailings go to the property owners, and they don't go to the tenants. The
859 apartments across the street, they would get the notice but the tenants would not. There is no
860 way for us to send notices to tenants because of the turnover. In addition to that, we
861 announced at the Planning Commission Meeting that we were having a day-long Open House
862 so that anyone that had any questions about our project, they could come in at their leisure.
863 We have gone above and beyond the zoning notices doing our level best to make sure that
864 everyone who wanted to be included was included.

865
866 Mayor Motley Broom asked, any questions?

867

868 Councilman Clay said the power line pipe that has been brought up by several people, my
869 observation on that is if you are in a certain space around the flight path, you are required to
870 get certification from the FAA and you did get that.

871
872 Mr. Buckley said yes, and we provided a copy.

873
874 Councilman Clay said that was no surprise to me that you got it because your power lines
875 are not going to be any higher than the high voltage lines that pass through that area. Are
876 you going to put the power lines under the road or over the road? I think they cross Delano.
877 Help me out.

878
879 Mr. Buckley said they will cross Welcome All Road (indicating on map).

880
881 Councilman Clay asked, when you cross the road, are you going to go above or bore under
882 it?

883
884 Mr. Buckley said given that we are still working towards signing on an end user and the reason
885 for that is this: If you are going to shop a facility to potential partners, they are willing to
886 entertain a few introductory or preliminary discussions about that. But until your entitlements
887 are real and they know that you can do the project, they are not going to waste a whole lot of
888 time talking to you. That is why we were saying that we don't have an end user. Mayor
889 Edwards expressed a strong preference that the connection from our facility to that substation
890 be buried. We said to him that we will use our best efforts to bury it, but if we have a partner
891 that wants that connection to be aerial, then that would be much harder for us to do.

892
893 Councilman Clay said I believe that line is probably 14,000 volts. You are going to step it
894 down to a local distribution, especially if you are using an existing substation, and that is
895 probably 12,000 or 14,000 volts. And that is very doable underground. So, it is more of an
896 issue of boring costs than anything else. And I would hope that for the benefit of the citizens
897 that it would be underground, as opposed to being overhead. And that is some of the issues
898 with your requirements for the FAA, if you don't have those towers going up.

899
900 Councilman Gay said I have a recommendation. From what I heard from the citizens, I think
901 they have expressed their concerns. If you continue to go with the project, we can continue
902 to talk about it in volumes. For me, I don't need any more information. I am voting no. I
903 think it is unfair to the citizens that need to work tomorrow. We need to make a decision on
904 this matter, or move it to another time and discuss it further.

905
906 Mayor Motley Broom asked, any other questions?

907
908 Councilman Clay said I pretty much asked all the questions that I have at this point.

909
910 Mayor Motley Broom declared the public hearing closed.

911
912 Mayor Motley Broom called for a motion.

913

914 Councilman Clay asked, does anybody want to defer it to the next meeting so we can
 915 determine those issues, like the plan for our Chief, and he can talk to their Chief. How do
 916 you handle an evacuation situation there? I just throw that out.

917 Councilman Taylor said I think we should deny it.

918

919 **ACTION:** Councilman Taylor moved to deny a request from City Planner Nikki Washington
 920 for the rezoning of 0 Welcome All Road from BP-Business Park to M1-Light
 921 Industrial Zoning District, seconded by Councilman Gay. Councilman Taylor
 922 voted no. Councilman Gay voted no. Councilman Clay opposed to deny.
 923 Councilman Allen opposed to deny. Mayor Motley Broom opposed to deny.
 924 Motion denied.

925

926 Mayor Motley Broom asked, is there another motion?

927

928 **ACTION:** Councilman Clay moved to defer a request from City Planner Nikki Washington
 929 for the rezoning of 0 Welcome All Road from BP-Business Park to M1-Light
 930 Industrial Zoning District, seconded by Councilman Allen. Councilman Clay voted
 931 yes to defer. Councilman Allen voted yes to defer. Councilman Taylor opposed.
 932 Councilman Gay opposed. Mayor Motley Broom moved to defer. Motion carried.

933

934 8. Bids, Change Order Requests And Contracts.

935

936 A. Consideration of and action on a request for approval to utilize GovHR USA for a City
 937 Manager national search and to authorize the Director of Human Resources & Risk
 938 Management Dr. Dwight Baker to negotiate an agreement with GovHR USA with
 939 substantially the same terms as the City's former services agreement in an amount not to
 940 exceed \$22,500.00.

941

942 **ACTION:** Councilman Clay moved to approve a request from Director of Human Resources
 943 & Risk Management to utilize GovHR USA for a City Manager national search and
 944 to authorize the Director of Human Resources & Risk Management Dr. Dwight
 945 Baker to negotiate an agreement with GovHR USA with substantially the same
 946 terms as the City's former services agreement in an amount not to exceed
 947 \$22,500.00, seconded by Councilman Taylor and motion carried. (All Voted Yes).

948

949 B. Consideration of and action on bids received for the selection of the City's annual
 950 supplier of unleaded gasoline and diesel fuel.

951

952 Councilman Gay asked, on this one, I did like the details. Was this bid out?

953

954 Director of Public Works Melissa Echevarria said yes.

955

956 Councilman Gay asked, was this the lowest responsive bidder?

957

958 Director of Public Works Melissa Echevarria said yes, sir.

959

960 **ACTION:** Councilman Clay moved to approve a request from Director of Public Works
 961 Melissa Echevarria to select Petroleum Traders Corporation as the City's primary
 962 supplier of unleaded gasoline and diesel fuel for an estimated annual cost of
 963 \$510,985.00. In the event of an emergency or security breach, Southern Petroleum
 964 Resources as a secondary source, seconded by Councilman Allen and motion
 965 carried. (All Voted Yes).
 966

- 967 C. Consideration of and action on a request for approval of bids received to perform street
 968 resurfacing work under the Georgia Department of Transportation (GDOT) 2021 Local
 969 Maintenance and Improvement Grant (LMIG) Program.
 970

971 **ACTION:** Councilman Clay moved to approve a request from Director of Public Works
 972 Melissa Echevarria for Mullins Brothers Paving Contractors to perform street
 973 resurfacing work under the Georgia Department of Transportation (GDOT) 2021
 974 Local Maintenance and Improvement Grant (LMIG) Program, in the amount of
 975 \$253,220.00, seconded by Councilman Gay and motion carried. (All Voted Yes).
 976

- 977 D. Consideration of and action to designate City Streets for resurfacing under the Georgia
 978 Department of Transportation's (GDOT) 2022 Local Maintenance and Improvement
 979 Grant (LMIG) resurfacing program.
 980

981 Councilman Gay said there may be a change in Streets that Ward 4 wants to submit, based on
 982 the information we have before we made this list.
 983

984 Director of Public Works Melissa Echevarria said this is for FY2022. The deadline is February
 985 22, 2022, so we have time to modify it.
 986

987 Councilman Gay said I would like to modify my street but approval to consideration.
 988

989 Councilman Clay said I will restate my motion then, if that is what we need to do, or make
 990 the motion to leave it open for Councilman Gay to change his street.
 991

992 **ACTION:** Councilman Clay moved to approve a request from Director of Public Works
 993 Melissa Echevarria to designate City Streets for resurfacing under the Georgia
 994 Department of Transportation's (GDOT) 2022 Local Maintenance and
 995 Improvement Grant (LMIG) resurfacing program, with the proviso for Councilman
 996 Gay to change streets, seconded by Councilman Taylor and motion carried. (All
 997 Voted Yes).
 998

- 999 E. Consideration of and action on a request for approval to renew the City's citizen
 1000 response software with QScend Technologies, Inc.
 1001

1002 **ACTION:** Councilman Allen moved to approve a request from Chief Information Officer
 1003 Michael Hicks to renew the City's citizen response software with QScend
 1004 Technologies, Inc. for the See Something/Say Something Software called I-Notify,

1005 in the amount of \$12,629.00, seconded by Councilman Clay and motion carried.
1006 (All Voted Yes).

1007
1008 F. Consideration of and action on a request for approval of the T-SPLOST Project
1009 Cooperation Agreement between the City of College Park and the Airport West
1010 Community Improvement District.

1011
1012 **ACTION:** Councilman Clay moved to approve a request from City Attorney Danielle
1013 Matricardi for the T-SPLOST Project Cooperation Agreement between the City of
1014 College Park and the Airport West Community Improvement District, seconded by
1015 Councilman Allen and motion carried. (All Voted Yes).

1016
1017 G. Consideration of and action on a request to ratify approval of the acceptance of
1018 Community Development Block Grant (CDBG) funds from the Fulton County
1019 Department of Community Development for Barrett Park improvements in the amount
1020 of \$102,700.00.

1021
1022 **ACTION:** Councilman Clay moved to approve a request from Director of Recreation &
1023 Cultural Arts Michelle Johnson to ratify approval of the acceptance of Community
1024 Development Block Grant (CDBG) funds from the Fulton County Department of
1025 Community Development for Barrett Park improvements in the amount of
1026 \$102,700.00, seconded by Councilman Gay and motion carried. (All Voted Yes).

1027
1028 9. Unfinished (Old) Business. None.

1029
1030 10. New Business.

1031
1032 A. Consideration of and action to review and approve a request for a conditional height
1033 permit for a proposed warehouse. Ward 2.

1034
1035 City Planner Nikki Washington came forward to explain the request.

1036
1037 Councilman Gay asked, what street?

1038
1039 City Planner Nikki Washington said it is in-between Roosevelt Highway and Buffington
1040 Center.

1041
1042 Councilman Gay said I don't have a problem with it.

1043
1044 **ACTION:** Councilman Allen moved to approve a request from City Planner Nikki Washington
1045 for a conditional height permit for a proposed warehouse, seconded by Councilman
1046 Clay and motion carried. (All Voted Yes).

1047
1048 B. Discussion of proposed Millage Rate and approval of recommended rate for
1049 advertisement for Fiscal Year 2021- 2022.

1050

1051 Mayor Motley Broom said the location may change.

1052

1053 Director of Finance and Accounting Althea Philord-Bradley said we can modify that.

1054

1055 Councilman Clay said I will modify my motion to revise it as appropriate to cover both cases.

1056

1057 **ACTION:** Councilman Clay moved to approve a request from Director of Finance &
1058 Accounting Althea Philord-Bradley to modify advertisement of proposed Millage
1059 Rate and approval of recommended rate for advertisement for Fiscal Year 2021-
1060 2022, seconded by Councilman Taylor and motion carried. (All Voted Yes).

1061

1062 C. Consideration of and action on a Resolution to authorize the College Park Business &
1063 Industrial Development Authority (BIDA) to refinance all of the obligations related to
1064 the previously issued Atlanta Land Purchase Revenue Bonds, Series 2014.

1065

1066 This item was deleted from the agenda.

1067

1068 D. Consideration of and action to ratify the City Manager's recommendations regarding the
1069 alcoholic beverage violation at 5021 Old National Highway (WRAITH).

1070

1071 Interim City Manager Mercedes Miller said City Clerk has some advertisements to give you.
1072 We are concerned because they are operating as a club than a restaurant. So, my
1073 recommendation is a \$5,000.00 fine and a 90-day suspension. These are the first 2 that I
1074 have. And I checked with City Clerk, and it is in line for these violations.

1075

1076 Councilman Gay asked, did we do it for the other one?

1077

1078 City Clerk Shavala Moore said their administrative hearing was deferred.

1079

1080 Councilman Gay asked, is this the first time before us?

1081

1082 City Clerk Shavala Moore said yes.

1083

1084 Councilman Clay said the only thing is cumulative is the remedy.

1085

1086 Councilman Taylor said they need a fine, but I think 90 days is too long. But they do need
1087 to pay some money. I don't oppose it.

1088

1089 Councilman Gay asked, have we done less time with other clubs?

1090

1091 City Clerk Shavala Moore said since I have been here, we have not.

1092

1093 Councilman Clay said this is like 3 different violations with multiple people involved.
1094 Someone served someone that was underage, and we rescinded their license for a month.
1095 That is a whole lot different than 3 straight violations, serving after hours, and serving
1096 underage.

1097 City Clerk Shavala Moore said I have about 11 violations here.

1098

1099 Councilman Clay said this is probably the most number of offenses, since I have been on
1100 Council.

1101

1102 **ACTION:** Councilman Clay moved to approve a request from City Clerk Shavala Moore to
1103 ratify the City Manager's recommendations regarding the alcoholic beverage
1104 violation at 5021 Old National Highway (WRAITH), seconded by Councilman
1105 Allen. Councilman Clay voted yes. Councilman Allen voted yes. Councilman
1106 Taylor opposed. Councilman Gay abstained. Motion carried.

1107

1108 E. Consideration of and action to ratify the City Manager's recommendations regarding the
1109 alcoholic beverage violation at 4807 Old National Highway (Knockouts).

1110

1111 Councilman Allen said we need to hold these people accountable.

1112

1113 **ACTION:** Councilman Clay moved to approve a request from City Clerk Shavala Moore to
1114 ratify the City Manager's recommendations regarding the alcoholic beverage
1115 violation at 4807 Old National Highway (Knockouts), seconded by Councilman
1116 Allen. Councilman Clay voted yes. Councilman Allen voted yes. Councilman
1117 Taylor opposed. Councilman Gay abstained. Motion carried.

1118

1119 11. City Attorney's Report.

1120

1121 A. Consideration of and action on an ordinance to declare a local state of emergency within
1122 the City of College Park due to the Covid-19 pandemic.

1123

1124 **ACTION:** Councilman Clay moved to approve a request from City Attorney Danielle Matricardi
1125 for an ordinance to declare a local state of emergency within the City of College Park
1126 due to the COVID-19 pandemic, seconded by Councilman Taylor and motion carried.
1127 (All Voted Yes).

1128

1129 12. City Manager's Report. None.

1130

1131 13. Report of Mayor and Council.

1132

1133 Councilman Clay – said listen, I'm concerned about the speed cushion spacing. Chief Elmore,
1134 when you originally presented this, the reason I liked it was that the emergency vehicles have
1135 a wider track, and they can run right through the middle and they don't hit a bump.
1136 Unfortunately, there are some things like Hummers that have the same width track, but there
1137 is nothing we can do about that. However, I can drive my Prius through and not have a bump.
1138 And my wheelbase is not anywhere as wide as an emergency vehicle. So, could you please
1139 check the spacing and see because you brought the proposal? Could you please check and
1140 see if it matches, if we put those humps down the way it's supposed to be? If my wheel track
1141 fits, and your wheel track doesn't fit, so when ambulances are going over those, they are
1142 hitting a bump. Could we please check into that?

1143 Fire Chief Wade Elmore said yes.
1144

1145 Councilman Clay said and they will have to figure it out. And maybe we will need to
1146 add some more of those rubberized panels to do it. That's all I have.
1147

1148 Fire Chief Wade Elmore said the middle ones could be a little bit wider. We will work with
1149 Public Works and see if we can add on to that middle cushion.
1150

1151 Councilman Allen said if you go in front of Madison, there are 2 there that you can go right
1152 through and one that you can't. The middle one is a little bit narrower, and I can drive over
1153 that with my car, and the other one I cannot.
1154

1155 Fire Chief Wade Elmore said the width of the street is a matter also.
1156

1157 Councilman Clay said on Lyle, I drove down the other day with somebody behind me, and I
1158 straddled the middle of the street just to see if I could go through it. If they are listening, I
1159 wasn't trying to violate the law, I was trying to prove my point.
1160

1161 Councilman Taylor – said I have nothing to report.
1162

1163 Councilman Allen – said I would like to thank the citizens of South Fulton for coming down
1164 and expressing their opinions. I applaud them for doing it. I listened to every single word.
1165 Thank you very much.
1166

1167 Councilman Gay – asked for an update on the portable camera. I am getting mixed answers
1168 from different people, please.
1169

1170 Interim Chief of Police Thomas Kuzniacki said what we have from Net Planner is \$28,000.00.
1171 You have another demonstration tomorrow. The time frame is 8 to 12 weeks for it.
1172

1173 Councilman Gay asked, can you give me an update on the Main Street Academy traffic? I
1174 have been getting calls today that it is still bad.
1175

1176 Interim Chief of Police Thomas Kuzniacki said it is my understanding that it is going
1177 smoother.
1178

1179 Councilman Clay asked, what camera are you talking about?
1180

1181 Interim Chief of Police Thomas Kuzniacki said a camera that will run on solar so we can
1182 move it.
1183

1184 Councilman Gay thanked the Clerk for doing an amazing job today for our qualifying. It was
1185 a very professional process.
1186

1187 Councilman Gay said that's all I have.
1188

1189 Mayor Motley Broom - said I think that anytime you can get a level of engagement on the
1190 issues we are dealing with, it helps us with a process. And I appreciate the fact that so many
1191 citizens from South Fulton did come up and talk about their particular issue.

1192
1193 Mayor Motley Broom said I also want to thank GMA because they did just a great job at the
1194 conference in Savannah. It was fantastic and very informative.

1195
1196 Mayor Motley Broom said I think we are going to have the Department of Community Affairs
1197 speak with our department heads and all that the DCA can provide, because I don't know that
1198 we are tapping into everything that they can do. We have a number of other initiatives that
1199 we are going to be starting as a result of the conference.

1200
1201 Mayor Motley Broom said it is great to see people and be in the same room again.

1202
1203 Mayor Motley Broom said that's all I've got. We need to approve executive session minutes.

1204
1205 14. Executive Session. None.

1206
1207 15. Approval of Executive Session Minutes.

1208
1209 **ACTION:** Councilman Clay moved to approve Executive Session Minutes dated August 16,
1210 2021, as presented, seconded by Councilman Allen and motion carried. (All Voted
1211 Yes).

1212
1213 16. Adjournment.

1214
1215 Mayor Motley Broom declared the Regular Session adjourned 10:12 p.m.

1216
1217
1218
1219
1220
1221
1222

CITY OF COLLEGE PARK

Bianca Motley Broom, Mayor

1223
1224
1225
1226
1227
1228
1229

1230 **ATTEST:**
1231
1232
1233 _____
1234 **Shavala Moore, City Clerk**

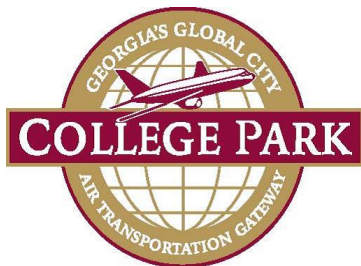

CITY OF COLLEGE PARK

P.O. BOX 87137 · COLLEGE PARK, GA 30337 · 404.767.1537

REG SESSION AGENDA REQUEST

DOC ID: 9049

DATE: September 1, 2021

TO: The Honorable Mayor and Members of City Council

THROUGH: Mercedes Miller, Interim City Manager

FROM: Gabrielle Thornton, Deputy City Clerk

RE: Workshop Session Minutes dated August 16, 2021

See attached Workshop Session Minutes dated August 16, 2021.

Thank you.

ATTACHMENTS:

- WSS081621 (DOC)

Review:

- Gabrielle Thornton Completed 08/24/2021 8:29 AM
- Rosyline Robinson Completed 09/01/2021 12:10 PM
- Mercedes Miller Completed 09/01/2021 1:39 PM
- Mayor & City Council Pending 09/07/2021 7:30 PM

1 CITY OF COLLEGE PARK
 2 MAYOR AND CITY COUNCIL
 3 WORKSHOP SESSION
 4 AUGUST 16, 2021
 5

6 **MINUTES**
 7

8 Present: Mayor Bianca Motley Broom; Councilmen Ambrose Clay, Derrick
 9 Taylor, Ken Allen, and Roderick Gay; Interim City Manager Mercedes
 10 Miller; City Clerk Shavala Moore; City Attorney Winston Denmark.
 11

12 Absent: None.
 13

14 Mayor Motley Broom called the workshop session to order at 5:00 p.m.
 15

16 **ACTION:** Councilman Clay moved to take up executive session to discuss personnel,
 17 pending litigation, and the potential purchase of real estate, seconded by
 18 Councilman Allen and motion carried. (All Voted Yes).
 19

20 Mayor & Council entered into executive session at 5:02 p.m.
 21

22 The workshop session reconvened at 6:02 p.m.
 23

- 24 **1. Presentation on Food Trucks from Ray Coleman. See memorandum dated**
 25 **August 11, 2021 from City Planner Nikki Washington. Also, see attached**
 26 **supporting documentation submitted by Mr. Coleman.**
 27

28 Mr. Coleman came forward and said I am a business owner in College Park on some land
 29 on Roosevelt Highway. And I propose to the City to consider changing the ordinance on
 30 food trucks. Food trucks are a growing industry in the city and the country. I'm
 31 proposing to put a food truck on a portion of my land.
 32

33 Mr. Coleman said the City of College Park does not allow food trucks in the city. I think
 34 there is a packet that we presented and a rendering for you, and you should be able to see
 35 that. I am asking you to reconsider the City's position on food trucks. I think it will be
 36 vital for the city. My land sits at the gateway. You renamed Main Street at the corner of
 37 Old National and Main Street.
 38

39 Mayor Motley Broom asked, any questions for Mr. Coleman?
 40

41 Councilman Taylor said I don't have any questions. The only part I see is temporary rest
 42 rooms. And if we decide to do this, would there be a permanent rest room in the future?
 43

44 Mr. Coleman said yes. I was asked to give some type of drawing so you could have some
 45 type of visual idea, but there will be a building there.
 46

47 Councilman Clay said I see you had other picnic benches set up for people. There is no
48 shade in the drawing. I can't see people sitting out and spending a lot of time in the sun.
49 Are you planning on providing some kind of pavilion to provide shade?

50
51 Mr. Coleman said those things we are still working out. I am getting some ideas on how
52 to make it a friendly type of environment because that is the purpose of it.

53
54 Councilman Allen asked, how many food trucks do you think you would have there at
55 any given time?

56
57 Mr. Coleman said the maximum is 8 food trucks.

58
59 Councilman Gay asked, will they come from a commissary or from different places?

60
61 Mr. Coleman said State Law requires that all food trucks have commissary. That will be
62 a requirement that they are in compliance with the State Ordinance, as far as food trucks
63 are concerned, yes.

64
65 Mayor Motley Broom said I was a little confused on packet page 4. And there are 2
66 drawings back-to-back. Where is the parking on the first one? You see cars lined up on
67 a fence in the second drawing.

68
69 Mr. Coleman said we won't be providing at this time permanent parking. I'm negotiating
70 with the land that the county owns to provide additional parking, but there is a right-of-
71 way there where cars come in and grab the food and go. If there are people walking, and
72 they want to utilize that area, we will have the awning area for you to sit down and eat.

73
74 Mayor Motley Broom said so the second picture with the cars aligned along the wall - -

75
76 Mr. Coleman said that is just an idea for you to have some kind of idea of what a food
77 truck parking looks like.

78
79 Mayor Motley Broom said I have been to the one that is off of I-75 and Howell Mill.
80 They have a good bit of parking there. If we are looking at the initial drawing, and just a
81 drive-thru for curbside pickup, that is going to back up pretty quickly.

82
83 Mr. Coleman said I agree. That is why we are negotiating for more land adjacent to my
84 property with the county.

85
86 Councilman Allen said the drawing shows a one way off of Roosevelt Highway coming
87 in and then exiting off into Herschel Road.

88
89 Mr. Coleman said yes, sir.

90
91 Mayor Motley Broom said if you wanted to sit and have your food there, you wouldn't be
92 able to do that at first.

93 Mr. Coleman said if you look at this drawing here (indicating) coming off Roosevelt, you
94 would come in and turn up. We are giving you that breezeway here (indicating), and we
95 will make it wide enough for 2 cars. Once we get with engineering, if approved, then we
96 will be able to determine how many cars will be able to sit stationary as other cars are
97 going by.

98

99 Mayor Motley Broom asked, any thoughts from the Body?

100

101 Councilman Taylor said I like it.

102

103 Mayor Motley Broom said I have a lot of questions. We certainly don't want a situation,
104 and right now we are dealing - - I was going along Main Street yesterday and there were
105 3 cars backed up blocking Main Street because they were trying to get takeout from a
106 restaurant. And that is a huge disruption to traffic already. If you had 8 food trucks, I
107 could see you getting the kind of business that would necessitate having spots for quite a
108 few vehicles to park and stay.

109

110 Mr. Coleman said Fulton County won't sell the property. But if they would sell it, they
111 would sell it to me. So, I believe we can negotiate, if not purchasing it, and work out
112 some type of lot lease so we can provide additional parking. Initially starting out, I don't
113 anticipate traffic problems because we have to build up the business.

114

115 Mayor Motley Broom said you can do that on Instagram.

116

117 Mr. Coleman said we would hope so. The land and the participants are going to have to
118 work together to bring traffic in.

119

120 Councilman Allen said what are your times and dates? How long would you be open?

121

122 Mr. Coleman said 6 days a week, so we can do cleanup and things like that.

123

124 Councilman Allen asked, do you plan on opening from 12:00 to 7:00?

125

126 Mr. Coleman said 10:00 a.m. to 8:00 p.m. at the latest.

127

128 Mayor Motley Broom said that area is not the best for pedestrians already, in terms of
129 access and safety. Ms. Washington, have you, from the planning perspective, the site
130 plan hasn't been done. Are there any particular things that you can think of?

131

132 City Planner Nikki Washington said for me, we are trying to gain, is there an interest?
133 Are we interested in an ordinance change or a possible conditional use permit for this
134 particular area? Is it worth it for Mr. Coleman to start this process and pay for this site
135 planning and to go through this process, or are we interested in seeing it? My No. 1
136 concern is traffic in this area. We have a lot of residents on Herschel Road that are
137 already really concerned about the traffic in their area. So, we want to make sure that we
138 address that. Good exits and entrances and parking as well. There is already a

139 conditional use on his property for raw material storage. I would suggest that he do this
140 instead of the other.

141
142 Councilman Clay asked, what is the raw material?

143
144 Mr. Coleman said that goes against the entire concept. I grew up in College Park. I
145 played for the rec center. The things that College Park is, it's a city that is thriving, but
146 we are slow to the new development. We are getting ready to open up a subdivision with
147 300 plus homes with warehouses down the street. All the businesses are going to East
148 Point. We need to be forward thinking like everybody else.

149
150 Mayor Motley Broom said absolutely Mr. Coleman. What raw materials are you storing
151 on the site now?

152
153 Mr. Coleman said rock, mulch, pine straw, and the like. Part of the day is going to be
154 food, and the other part of the day is grabbing some mulch. It's a flowing situation with
155 the lot. Me personally, I don't see a conflict, and the area needs it. Our residents need
156 the things that I am talking about offering in this area. We need to be forward thinking
157 about how we can make it work, instead of shutting down the idea. The parking can be
158 worked out, if I work the deal with the county.

159
160 Mayor Motley Broom said that's a big "if". If that part doesn't come through, then we
161 might end up with a situation. How big is the property?

162
163 Mr. Coleman said an acre.

164
165 Councilman Clay asked, what is the backup situation? I'm not even talking about the
166 congestion that this establishment might cause, but how is the backup situation on that
167 section of Roosevelt Road? There are times when there is a mile or 2 miles backup on
168 Roosevelt Road. Councilman Gay is probably more aware than anybody.

169
170 Councilman Taylor said once you get in the City of South Fulton, that is where a lot of
171 the congestion is.

172
173 Councilman Clay asked, so you don't think there is a backup Councilman Taylor?

174
175 Councilman Taylor said no.

176
177 Mayor Motley Broom asked, this is close to the furniture store, right?

178
179 Councilman Gay said there are several vacant lots directly across the street, and there is
180 an opportunity to talk to them about additional parking. Dairy Queen only has 8 parking
181 spaces, but they get a tremendous amount of traffic. So, I'm thinking, if it can work for
182 them, it can work for you.

183
184 Mr. Coleman said I agree.

185 Councilman Allen said if I need pine straw or some rock, I am going to take my truck,
186 and they can put a load up in there. Do you have a space where you can back up?

187

188 Mr. Coleman said yes, sir.

189

190 Councilman Gay said there is a raw material place on Memorial Drive. But I will tell
191 you, you do need quite a bit of land because the tractor has to load it, and the tractor-
192 trailers come in and dumps the mulch. Aesthetically, I like both of them. The large
193 trucks do bring the rock, and they have to have scales. I just want to make sure you can
194 plan it properly.

195

196 Mr. Coleman said I don't have enough land like Commons does.

197

198 Councilman Gay said that's cool.

199

200 Mr. Coleman said I am a landscaper by trade.

201

202 Councilman Clay said I'm not ready to approve it tonight. So, the question is: Do you
203 want him to put forth the extra work to bring a more solid proposal that we can approve?

204

205 Councilman Allen said I'd like to hear more.

206

207 Councilman Taylor said he is just talking about the food truck side of it.

208

209 Mayor Motley Broom said the planning department needs to dive into this a little bit
210 more. When we see changes in our ordinances to accommodate particular items, we
211 usually see an analysis from planning. That hasn't happened yet.

212

213 Councilman Clay said I also think we need to revisit the question; why don't we have
214 something like this now to his point? He is saying, well, we are slow to adopt it. But I
215 remember when we have had lengthy discussion on food trucks. One of them was
216 concerned on competition for local businesses. And these were food trucks that would go
217 to a park or someplace like that, as opposed to an actual area that was designated. So,
218 that I see as different. But I think we ought to revisit whether we have issues with having
219 food trucks at all, regardless of whether they are in his spot or not.

220

221 Councilman Clay further said considering the healthy business and the clientele that we
222 are getting at least on Main Street, and I don't know as well about Virginia, I don't think
223 he would be a threat to those businesses. That would be my feeling right now. Whether
224 he might be a threat to Dairy Queen or some other places around; that is another issue. I
225 am fine for going forward and digging into it more.

226

227 It was the consensus of Mayor & Council for staff to dig in and do more research into
228 Mr. Coleman's request and bring it back to Council.

229

230 **2. Presentation by Chisulo Ajanaku, Principal Agent with United Action for**
 231 **Advancement of Humanity, Inc., on establishing a Pedicabs Ambassador**
 232 **Program in College Park. See memorandum dated August 11, 2021 from**
 233 **City Planner Nikki Washington. Also, see attached supporting**
 234 **documentation submitted by Mr. Ajanaku.**
 235

236 Dr. Chisulo Akono Ajanaku, 1840 Mercer Avenue, College Park, Ga., came forward and
 237 gave a power point presentation on Pedicabs. I serve as a principal agent of United
 238 Action for the Advancement of Humanity, a nonprofit agency that was incorporated here
 239 in College Park in 2019. It is about the unity and coming together as one race: human.
 240

241 Dr. Ajanaku said today I have Vince Wiley (Co-Founder and Lead Visionary); and
 242 Michael Schaller (Co-Founder and Lead Operations) of Joyride Pedicabs, LLC. They are
 243 currently operating at Truist Park and at the Braves Stadium. They have agreed to be a
 244 partner with our organization. I also have one of my board members Michael Malvin (sp)
 245 here with us. They will help me in this presentation.
 246

247 Dr. Ajanaku said we are here to answer your questions and to request that you approve
 248 creating a Pedicab ordinance.
 249

250 Dr. Ajanaku discussed the benefits and identifiable uses of the Pedicabs.
 251

252 Dr. Ajanaku discussed the experience of collaborating partners. Thank you for this
 253 opportunity.
 254

255 Mayor Motley Broom asked, any questions from the Body?
 256

257 Councilman Clay said I have a comment and a question. I think your vision - - And we
 258 worked together on this to some degree. We talked about having ambassadors in the city,
 259 welcomers, and we were thinking of pedestrian welcomers. And you are envisioning, I
 260 think, that the Pedicab drivers would be very knowledgeable of College Park, and they
 261 could take people on a tour, for example, of Woodward Academy, their campus, and they
 262 could drive people down the street and identify the different houses and architect
 263 novelties. How are you going to assimilate that or create that training package?
 264

265 Dr. Ajanaku said first, we are going to address the problem, and that problem is in our
 266 Main Street area where there is not ample parking. And with a growing population of
 267 people coming to our area and visiting our restaurants, we envision at the beginning
 268 stages to provide a service to not only those citizens coming to take part in the
 269 restaurants, merchants on Virginia, and the people in the hotels. So, we want to focus on
 270 involving the problem of getting people to our area to purchase meals and to see our
 271 attractions here.
 272

273 Dr. Ajanaku discussed providing tours and more education about the historic homes.
 274

275 Councilman Clay said that is kind of the second phase of the plan, if you will.

276 Dr. Ajanaku said yes.

277

278 Councilman Allen asked, would the Pedicabs be owned by a company, or would they be
279 individually owned? And would the Pedicabs be parked at a person's house, or parked
280 somewhere on the street, or on a side street? How would that work?

281

282 Mr. Vince Wiley said the Pedicabs are based in Marietta at the Braves Stadium/Truist
283 Park. We are partnering with Dr. Chisulo. And we will use our Pedicabs to service
284 College Park.

285

286 Councilman Allen asked, would you do maintenance on them in College Park, or store
287 them in College Park in a garage somewhere?

288

289 Mr. Wiley said we will use 2 Pedicabs to start the program, and we will be housing those
290 2 somewhere in College Park.

291

292 Dr. Ajanaku said we have identified 2 locations for storage. We have our office at the E-
293 Club, and there is a possible place in that area. But once we get started, we have a lot of
294 space in our carport, so we will be storing them in our carport. And Vince was generous
295 to bring one of the Pedicabs to the city, and we took some people for a ride. It will be a
296 great fit.

297

298 Councilman Allen asked, if I wanted to ride, do I hail you on the street, or pick up my
299 phone and set up an appointment for a certain time? How would that work?

300

301 Mr. Wiley said it could be both. You could set up an appointment, or if we are down on
302 Main Street and somebody wants to take a ride, yes, you can do both.

303

304 Councilman Allen asked, do you pay at the drop off? And if I said I'd like to go to a
305 store and pick up a hamburger and then leave, or if I wanted to take a tour, do I pay by
306 the hour? How does that work?

307

308 Mr. Wiley said that is something that we are working out. At The Battery, our concept is
309 a little different. We are pretty much the shuttle service for the people that come to the
310 games and come to the restaurants and bars.

311

312 Mayor Motley Broom said because you have to park a mile away.

313

314 Mr. Wiley said absolutely. The model might be slightly different, and we are working on
315 the payment. Everybody is cashless now. It is probably going to be digital, as opposed
316 to cash.

317

318 Dr. Ajanaku said one of the concerns for the Main Street Board, they want a cashless
319 option for all the Pedicab drivers. Our goal is to be a cashless operation.

320

321 Councilman Clay said we don't want the drivers to be a target.

322 Mayor Motley Broom said looking at 29 with the food park, it's a very different
323 environment than Truist Park. Do you have safety concerns for the Pedicab drivers being
324 on 29?

325

326 Dr. Ajanaku said our plan is not to be on 29. It is to cross 29 on East Main Street. If you
327 look at your maps, we have identified the streets that we would like you to approve in the
328 ordinance. Jackson and Councilman Clay gave me those streets, and Vince and I took the
329 Pedicab around those streets that Jackson said would be College Park city streets that
330 wouldn't be a problem. I wined up calling GDOT to find out if there was any problem,
331 if we were on one of the state streets, and they said we will have the same privilege as a
332 taxicab. But for safety's sake, we are going to stay on those less traveled streets.

333

334 Councilman Clay said the map that is on packet page 20, I think it's a little bit
335 misleading. It looks like they are on West Main Street or 29, but the actual intent is for
336 them to be on East Main Street.

337

338 Dr. Ajanaku said yes.

339

340 Councilman Clay said near the AC Hotel, there is a traffic light that crosses the railroad
341 track there, and then you come into the campus. So, the name of the game is to keep
342 them off of West Main Street/29 and use College and East Main Street as north/south.

343

344 Dr. Ajanaku said there are 5 maps that should have been in your packet. They are
345 highlighted in bright red. It maps out those routes to not only the Gateway Center but all
346 the way up to Virginia Avenue and Bobby Dodd.

347

348 Mayor Motley Broom said if someone was staying at the Marriott and wanted to go to
349 Virgil's, how close could you get them, if you are not traveling on East Main?

350

351 Dr. Ajanaku said we could crossover and come up one of those side streets and let them
352 walk.

353

354 Councilman Clay said let them walk on Harvard. If they were coming from Indigo, that
355 is pretty much a no brainer. If somebody was having a wedding at the Women's Club, if
356 it's a large wedding, they park blocks and blocks away sometimes for that. That would
357 be another opportunity for you. That is something we discussed with Jackson and
358 Jackson identified the best crossing point, which I liked because there was a traffic light
359 there. I would not feel comfortable riding a Pedicab on 29.

360

361 Councilman Clay asked, do we think that Pedicabs are a viable idea? And obviously the
362 fact that I'm involved with the process, I must think it is. I think it would be a novel
363 thing for College Park with all the visitors we are getting. And eventually they will have
364 the ability to cross Camp Creek Parkway on the pedestrian bridge. So, there are a whole
365 lot of possibilities of linking people with the Arena and with the GICC. It would be a
366 really neat way for people to visit College Park and see what we have here. We may

367 regret that. The idea is: Do we want a Pedicab, and if we want to do that, we should
368 probably have an ordinance to regulate them.

369
370 Councilman Allen asked, would they have lights at night?

371
372 Mr. Wiley said absolutely.

373
374 Mayor Motley Broom asked, is anybody interested in going forward?

375
376 Councilman Allen said I think it's a neat idea.

377
378 Councilman Gay said I agree. It is interesting.

379
380 Dr. Ajanaku asked, does that mean you will move forward with designing and creating
381 the ordinance?

382
383 Councilman Clay said you have a sample ordinance from Atlanta.

384
385 Dr. Ajanaku said no, from Savannah.

386
387 Councilman Clay said we can turn this over to City Attorney, and he can work us up an
388 ordinance.

389
390 Mayor Motley Broom said I think the City of Atlanta would have an ordinance on food
391 trucks as well.

392
393 Councilman Clay said I think they do.

394
395 Dr. Ajanaku said thank you Mayor & Council.

396
397 Mayor Motley Broom said thank you.

398
399 Mayor Motley Broom asked, are there any other issues in the workshop session to take
400 up?

401
402 City Clerk Shavala Moore said we have none.

403
404 Mayor Motley Broom said we have a little bit more to discuss in regard to executive
405 session, if I could get a motion to enter into executive session.

406
407 **ACTION:** Councilman Clay moved to adjourn Workshop Session to take up Executive
408 Session to discuss personnel, pending litigation, and the potential purchase
409 of real estate, seconded by Councilman Taylor and motion carried. (All
410 Voted Yes).

411
412 Mayor Motley Broom declared the Workshop Session adjourned at 6:44 p.m.

413
414
415
416
417
418
419
420
421
422
423
424
425
426

CITY OF COLLEGE PARK

Bianca Motley Broom, Mayor

ATTEST:

Shavala Moore, City Clerk

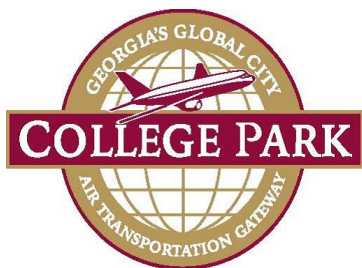

CITY OF COLLEGE PARK

P.O. BOX 87137 · COLLEGE PARK, GA 30337 · 404.767.1537

PROCLAMATION

DOC ID: 9053

DATE: September 1, 2021

TO: The Honorable Mayor and Members of City Council

THROUGH: Mercedes Miller, Interim City Manager

FROM: Shavala Moore, City Clerk

RE: Georgia Cities Week October 3-9, 2021

GEORGIA CITIES WEEK

October 3 - 9, 2021

A PROCLAMATION OF THE CITY OF COLLEGE PARK RECOGNIZING GEORGIA CITIES WEEK, OCTOBER 3 - 9, 2021 AND ENCOURAGING ALL CITIZENS TO SUPPORT THE CELEBRATION AND CORRESPONDING ACTIVITIES.

WHEREAS, city government is the closest to most citizens, and the one with the most direct daily impact upon its residents; and

WHEREAS, city government is administered for and by its citizens, and is dependent upon public commitment to and understanding of its many responsibilities; and

WHEREAS, city government officials and employees share the responsibility to pass along their understanding of public services and their benefits; and

WHEREAS, Georgia Cities Week is a very important time to recognize the important role played by city government in our lives; and

WHEREAS, this week offers an important opportunity to spread the word to all the citizens of Georgia that they can shape and influence this branch of government which is closest to the people; and

WHEREAS, the Georgia Municipal Association and its member cities have joined together to teach students and other citizens about municipal government through a variety of different projects and information; and

WHEREAS, Georgia Cities Week offers an important opportunity to convey to all the citizens of Georgia that they can shape and influence government through their civic involvement.

NOW, THEREFORE, BE IT PROCLAIMED, by the Mayor and Council of the City of College Park, Georgia that the week of October 3 -9, 2021 is hereby proclaimed:

GEORGIA CITIES WEEK

BE IT FURTHER PROCLAIMED THAT THE CITY OF COLLEGE PARK ENCOURAGES ALL CITIZENS, CITY GOVERNMENT OFFICIALS AND EMPLOYEES TO DO EVERYTHING POSSIBLE TO ENSURE THAT THIS WEEK IS RECOGNIZED AND CELEBRATED.

PROCLAIMED THIS 7th DAY OF SEPTEMBER, 2021.

ATTEST:

Shavala Moore, City Clerk

Bianca Motley Broom, Mayor

Ambrose Clay, Councilman

Derrick Taylor, Councilman

Ken Allen, Councilman

Roderick Gay, Councilman

ATTACHMENTS:

- Georgia Cities Week Info (PDF)

Review:

- Shavala Moore Completed 08/20/2021 12:22 PM
- Rosylina Robinson Completed 09/01/2021 12:08 PM
- Mercedes Miller Completed 09/01/2021 1:40 PM

- Mayor & City Council Pending 09/07/2021 7:30 PM



October 3 – 9, 2021

Our Mission:

The Georgia Municipal Association (GMA) is sponsoring Georgia Cities Week from October 3-9, 2021 to showcase and celebrate cities and the many services they provide.

Cities provide an elevated level of service than most governments, are generally rated higher by the public than any other level of government, and yet, many residents are unaware of how city services impact their lives. Through Georgia Cities Week, GMA and related organizations hope to heighten the public's awareness of city government's role in enhancing the quality of life in communities.

GMA's Georgia Cities Week is part of an ongoing effort to raise public awareness about the services that cities perform and to educate the public on how city government works. Cities are encouraged to involve their local schools, businesses, legislators, Chambers of Commerce, media and civic clubs in planning Georgia Cities Week activities.

2021

THE VALUE OF GEORGIA'S CITIES

CITIES PLAY A VITAL ROLE IN THE STATE'S ECONOMY.



Georgia cities comprise only **9.2%** of the land area in Georgia.



Cities contain **44.1%** of the population in Georgia.



Cities provide **68.9%** of jobs in Georgia.



75.1% of Georgia cities have a population of 5,000 or less.



Cities account for **90.5%** of GDP in Georgia.

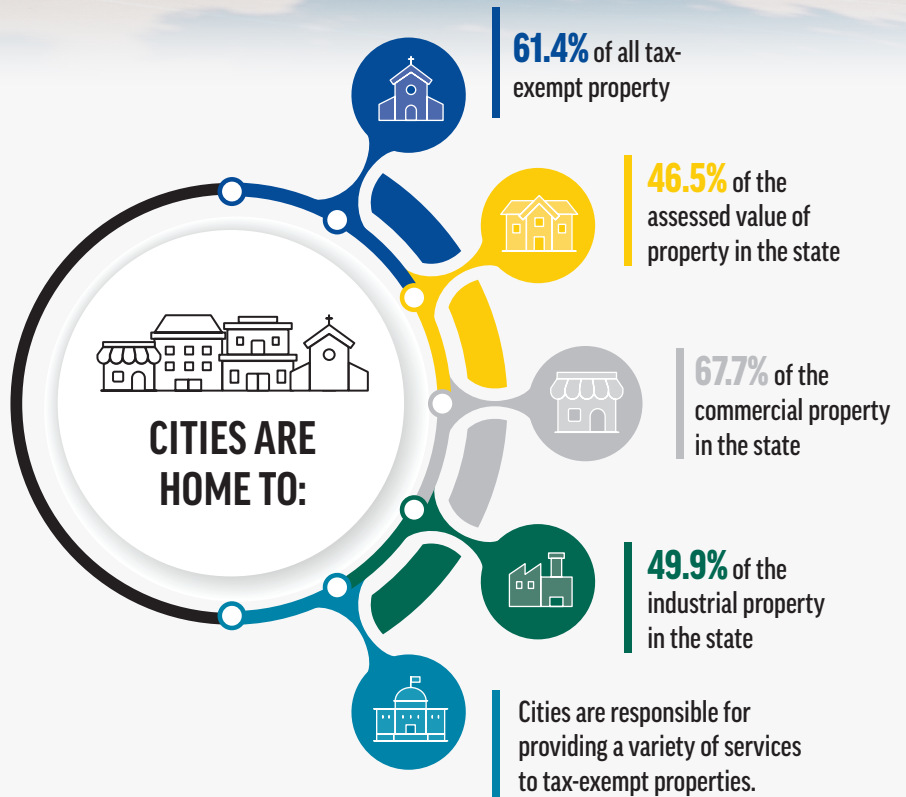

CITIES ARE GROWING AT A FASTER RATE THAN THE STATE'S OVERALL POPULATION:



Population growth in cities was **20.6%** between 2009 and 2019



Population growth in the state was **10.4%** between 2009 and 2019.

27.5%

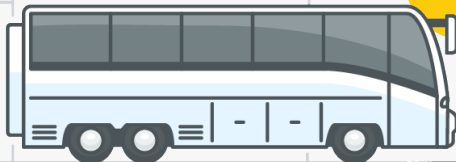

The population in Georgia cities increases during the daytime by 27.5% due to commuting, and cities provide services (water, sewer, fire and police protection, etc.) to both daytime and resident population.

LOCAL GOVERNMENTS ARE INVESTING IN THE FUTURE:

MUNICIPAL REVENUES BY SOURCE, FY2019

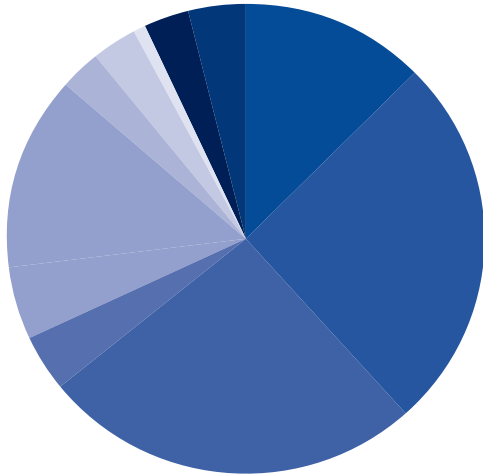

- Federal IGR 3%
- Service Charges 3%
- Other Revenue 3%
- Property Taxes 23%
- Sales Tax 27%
- Franchise Fees 5%
- Excise Taxes 14%
- License, Permits, Fees 3%
- State IGR 3%
- Local IGR 1%

MUNICIPAL EXPENDITURES BY CATEGORY, FY2019

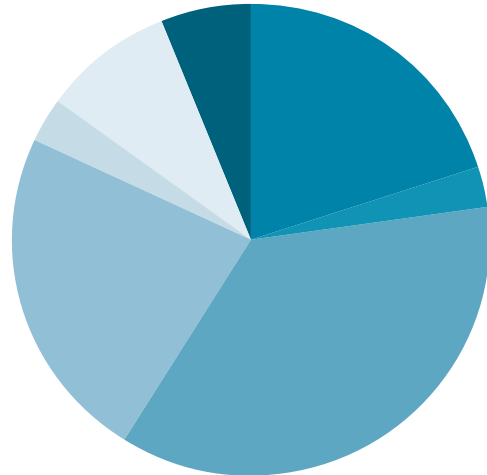

- Administration 20%
- Courts 3%
- Public Safety 36%
- Public Works 23%
- Health & Welfare 3%
- Culture & Recreation 9%
- Housing & Development 6%

SPLOST AND TSPLOST REVENUES

94%

of SPLOST referenda have been approved by local voters since 2001.

7.1

billion dollars in SPLOST revenues were distributed to local governments to pay for voter-approved capital projects between 2016 and 2020

28

Georgia counties have Single County TSPLOST in place (as of December 2020)

92

counties are either in a Single County TSPLOST or TIA Region (as of December 2020).

4

regions have implemented a Regional (TIA) TSPLOST (as of December 2020)

Local funds will not be enough – a long-term, strong local-state-federal partnership is needed to address our state's infrastructure needs.





CITY OF COLLEGE PARK

P.O. BOX 87137 · COLLEGE PARK, GA 30337 · 404.767.1537

REG SESSION AGENDA REQUEST

DOC ID: 9088

DATE: September 1, 2021

TO: The Honorable Mayor and Members of City Council

FROM: Mercedes Miller, Interim City Manager

RE: Consideration of an action to honor of the late Jack P. Longino

The purpose of this memorandum is to present to Mayor and Council for consideration and approval two options to honor the 28 years of dedicated service of former and late Mayor Jack P. Longino. Option 1: The naming of City Hall in his honor. Option 2: The naming of Council Chambers in his honor.

Thank you.

Review:

- Mercedes Miller Completed 09/01/2021 1:43 PM
- Rosyline Robinson Completed 09/01/2021 1:35 PM
- Mercedes Miller Completed 09/01/2021 1:44 PM
- Mayor & City Council Pending 09/07/2021 7:30 PM



CITY OF COLLEGE PARK

P.O. BOX 87137 · COLLEGE PARK, GA 30337 · 404.767.1537

REG SESSION AGENDA REQUEST

DOC ID: 9069

DATE: September 1, 2021

TO: The Honorable Mayor and Members of City Council

THROUGH: Mercedes Miller, Interim City Manager

FROM: Althea Philord-Bradley, Director of Finance & Accounting

RE: Delinquent Property Tax Payers Update

REASON: To provide Mayor and Council with the names, addresses, and outstanding balances of the top ten delinquent property tax payers as well as a brief update on collection efforts.

RECOMMENDATION: To proceed with established policies and procedures to ensure collection of these accounts. To escalate the collection process as appropriate to minimize the loss of revenue.

BACKGROUND: The City of College Park contracts with GTS (Government Tax Services) to facilitate the collection of delinquent accounts to the extent necessary. Past collection efforts have included GTS providing assistance with filing liens and assisting with tax sales.

COST TO CITY: Varies with each situation.

BUDGETED ITEM: None.

REVENUE TO CITY: As of August 9th, 2021, the City has collected 97% of 2020's Ad Valorem taxes due.

CITY COUNCIL HEARING: September 7, 2021.

OR RESOLUTION: N/A

REQUIRED CHANGES TO WORK PROGRAMS: Aggressive collection efforts to full extent of the law.

STAFF: Philip Latona, Property Tax Accountant

ATTACHMENTS:

- Top Ten Delinq Property Tax Accounts 08262021 (PDF)
- Top Ten Delinq Property Tax Accounts 08262021 2018(PDF)

Review:

- Althea Philord-Bradley Completed 09/01/2021 11:46 AM
- Rosyline Robinson Completed 09/01/2021 12:07 PM
- Mercedes Miller Pending
- Mayor & City Council Pending 09/07/2021 7:30 PM

**City of College Park
 Department of Finance & Accounting
 Top Ten Delinquent Property Tax Accounts
 As of August 26, 2021**

Lien	Taxpayer Name	Property Address	Business Name If Known	Amount	District - Tax Type	Additional Comments	Tax Years
Y	YC Atlanta	1419 Virginia Ave	Clarion Hotel	\$ 111,605.90	Fulton - Real & Personal	Official Bankruptcy claim. 5/20/21 Still reaching out to Debtor in Possession to get payment/release of payment status	2020
Y	ExpressJet	0 Candler Way		\$ 72,596.52	Fulton - Real	Uncollectible - County Assessor reclassified property to Exempt status. Owner seeking refund on paid taxes 2017-2019 (\$225K). 6/23/21 Requested response from Chief & Deputy Chief Appraiser on taxability issues on Capital Improvements utilizing Statute 6.3.25 - Allows for the taxation on Improvements - Legal is involved in pursuing matter too	2020
Y	Hydro Generation Inc	2561 West Point Ave	f/k/a Atlantis Hydroponics Pensacola LLC	\$ 4,571.24	Fulton - Personal	8/19/21 Identified Owner and new mailing addresses. Sending out statements and calling place of business. Working account.	2019-2020
Y	Uncle Maddios Pizza	Hartsfield ConcT		\$ 3,340.03	Clayton - Personal	8/19/21 Calling District Mgr, Emailing & Mailing Statements. Concessionaire Joint Venture operation. There was an April 2019 Chp 11 filing - we were not listed as a creditor	2019-2020
Y	XpresSpa	Concourse A		\$ 3,146.25	Clayton - Personal	7/26/21 - Resubmitted statement to Corporate - Treasurer/Sr. Director of Finance	2020
Y	Kelly George & Carolyn	2299 Godby Rd		\$ 1,895.04	Fulton - Real	8/13/21 Emailed property statement to owner	2020
Y	IHOP Express	Atrium	Global Concessions	\$ 1,239.52	Clayton - Personal	8/19/21 Client's Director of Finance & Accounting stated operation is still closed - will try to get it paid in the next couple of weeks	2020
Y	Olalude Victor	2465 Roosevelt Ave		\$ 1,200.44	Fulton - Real	Tax Deed Owner hoping property gets purchased a Tax Sale - Claims he can't seem to sell it with zoning changes and pandemic issues	2020
Y	Richard Andrew E	3543 College St		\$ 1,063.67	Fulton - Real	Phone call attempts have failed - not sure if # is in service. I have resent statements to Property and another address I found on owner	2020
Y	Cozumel The Mexican Cantina	5098 Old National Hwy		\$ 1,008.86	Fulton - Personal	8/26/21 Calling place of business- getting payment status	2020

\$ 201,667.47

Represents Lien filed against account.

Inactive Account - off active list - candidates to write-off

Level Concrete Co.	2560 West Point Avenue	Proximity of Metro Mustang	\$ 25,080.74	Fulton - Personal Property	Corporation dissolved 5/16/2008	2000-2003
Western Pacific	Airline		39,223.87	13K Base Ad Valorem	Chapter 11 - February 1998	
Vanguard Airlines	Airline		9,237.43	Public Utility Digest - Clayto	Ceased Operations July 29, 2002	
PSINet Inc			12,022.94	Fulton - Personal Property		
Larry Jones	0 Camp Creek Pkwy		11,264.14	Fulton - Real	Parcel Mapping indicates plat is a public roadway/right of	1992-2014
F H Kilgore	0 Camp Creek Pkwy		6,418.38	Fulton - Real	Parcel Mapping discrepancy	1992-2014

City of College Park
Department of Finance & Accounting
Top Ten Delinquent Property Tax Accounts
As of August 26, 2021

Lien	Taxpayer Name	Property Address	Business Name If Known	Amount	District - Tax Type	Additional Comments	Tax Years
Y	Smart Moves Investments LLC	2879 Windsor Forrest Ct		\$ 2,347.00	Fulton - Real	Identified Owner - he is a First Transferee Foreclosure - ownership confirmed /working account. In Sept. 7 Tax Sale	2018-2020



CITY OF COLLEGE PARK

P.O. BOX 87137 · COLLEGE PARK, GA 30337 · 404.767.1537

REG SESSION AGENDA REQUEST

DOC ID: 9067

DATE: September 1, 2021

TO: The Honorable Mayor and Members of City Council

THROUGH: Mercedes Miller, Interim City Manager

FROM: Althea Philord-Bradley, Director of Finance & Accounting

RE: Top 10 Delinquent Customers

PURPOSE: To update Mayor/Council regarding Top 10 delinquent customers, commercial and residential.

REASON: To keep updated on Top 10 commercial and residential accounts to ensure the accounts balances are current.

RECOMMENDATION: To deliver information to Mayor/Council by Customer Service team.

BACKGROUND: Each council meeting we deliver data that indicates who the Top 10 customers are based on balances owed, length of time unpaid.

COST TO CITY: N/A.

BUDGETED ITEM: N/A.

REVENUE TO CITY: N/A.

CITY COUNCIL HEARING DATE: September 7, 2021.

CONSIDERATION BY OTHER GOVERNMENT ENTITIES: N/A.

AFFECTED AGENCIES: N/A.

RELATIONSHIP TO EXISTING ORDINANCE OR RESOLUTION: N/A.

REQUIRED CHANGES TO WORK PROGRAMS: N/A.

STAFF: Customer Service Manager

ATTACHMENTS:

- Top Ten 07-12-2021 - redacted (PDF)
- CF AGING 083021 REDACTED (PDF)
- RF AGING 083021 REDACTED (PDF)
- CC AGING 083021 Redacted (PDF)
- RC AGING 083021 (PDF)

Review:

- Althea Philord-Bradley Completed 09/01/2021 12:06 PM
- Rosyline Robinson Completed 09/01/2021 1:09 PM
- Mercedes Miller Completed 09/01/2021 1:41 PM
- Mayor & City Council Pending 09/07/2021 7:30 PM

City of College Park											
TOP TEN UTILITY CUSTOMER OUTSTANDING BALANCES											
7/12/2021											
Prepared By Kimberli Johnson											
Business											
Prior Adjustments	Payment Plan	Liens	BUSINESS NAME	ADDRESS	Power	Water & Sewer	Storm Water & Sanitation	Total Unpaid	CUT OFF LETTER	AGE OF DEBT	Notes or Status
n/a	No	No			\$0.00	\$0.00	\$13,683.67	\$13,683.67	Yes	90days	Account is Active newly established Stormwater account. Last pymt was 06-25-21.
n/a	No	No			\$1,953.09	\$0.00	\$0.00	\$1,953.09	No	30days	Account is Active no paymt has ben made since the account was established 01-14-21.
n/a	No	No			\$0.00	\$1,863.30	\$0.00	\$1,863.30	Yes	90days	Account is Active Last pymt was 04-15-21for \$372.66.
n/a	No	No			\$0.00	\$0.00	\$1,950.87	\$1,950.87	Yes	90days	Account is Active newly established Stormwater account. Last pymt has been made as of 07-06-21 \$8255.48.
Apartments											
Prior Adjustment	Payment Plan	Liens	APARTMENT NAME	ADDRESS	Power	Water & Sewer	Storm Water & Sanitation	Total Unpaid	CUT OFF LETTER	AGE OF DEBT	Notes or Status
No	No	No			\$9,873.43	\$6,487.27	\$3,737.52	\$20,098.22	Yes	90 days	Account is Active last pymt for 93.15 was made on 06-11-21.
No	No	No			\$0.00	\$0.00	\$9,432.20	\$9,432.20	Yes	90 days	Account is Active last pymt for \$4716.10 was made on 05-17-21.
No	no	No			\$2,069.15	\$1,425.74	\$242.64	\$3,737.53	Yes	90 days	Account is Disconnected a reminder letter was sent on 06-18-21. Customer made a pymt for 100.00 on 09-16-2020 customer is a Senior. Customer was charged a \$1000.00 tampering fee.
No	No	No			\$246.53	\$1,387.41	\$426.35	\$2,060.29	No	90 days	Account is Active . Last pymt 04-30-21 \$1500.00 No reminder letter has been sent.
No	No	No			\$2,605.65	\$0.00	\$0.00	\$2,605.65	Yes	90 days	Account is Active a reminder letter was sent on 06-18-21.Last pymt of \$400.00 was made on 04-08-21. Senior customer.
No	No	No			\$1,244.61	\$903.51	\$55.15	\$2,203.27	Yes	90 days	Account is Active a reminder letter was sent on 06-18-21. Customer was recently recd. Cdbg grant for \$2,000.00. Last pymt \$1403.74 on 06-01-21.
TOTALS					\$17,992.46	#####	\$29,528.40	\$59,588.09			
		NUL	Signifies that Lien has not been filed due to legal statue (not property owner)								
		*	Represents Lien filed against account								
		N/A	Signifies account Lien has not been filed								
		yes	Signifies account received prior billing adjustment								
		N/A	Signifies account that has not received prior billing adjustment								

City of College Park

A / R A G I N G

08/30/2021 08:40:31

Page: 1

Cyc	Rte	Account Name	Home Phone	0 to	30	31 to	60	61 to	90	Over	91	Total	--- Last Payment --- Date	Amount
-----	-----	--------------	------------	------	----	-------	----	-------	----	------	----	-------	------------------------------	--------

Cycle: 1

0 Subtotals for Cycle 001

0.00	0.00	0.00	0.00	0.00
------	------	------	------	------

Cycle: 8

1234.98	1231.87	981.39	0.00	3448.24	06/01/2021	1639.98	O
158197.00	43792.87	0.00	0.00	201989.87	08/10/2021	14091.28	

2 Subtotals for Cycle 008

159431.98	45024.74	981.39	0.00	205438.11
-----------	----------	--------	------	-----------

Cycle: 15

1081.36	468.80	468.80	31.20	2050.16	05/25/2021	5129.94	O
3840.20	2170.10	2170.10	9343.47	17523.87	08/02/2021	1670.10	O
1931.73	967.68	136.73	0.00	3036.14	06/17/2021	1367.28	O

3 Subtotals for Cycle 015

6853.29	3606.58	2775.63	9374.67	22610.17
---------	---------	---------	---------	----------

Cycle: 21

68.00	34.00	34.00	996.10	1132.10	08/02/2021	50.00	O
745.32	372.66	372.66	1117.98	2608.62	04/15/2021	372.66	T

2 Subtotals for Cycle 021

813.32	406.66	406.66	2114.08	3740.72
--------	--------	--------	---------	---------

7 Grand Totals

167098.59	49037.98	4163.68	11488.75	231789.00
-----------	----------	---------	----------	-----------

City of College Park

A / R A G I N G

08/30/2021 08:40:49

Page: 2

Cyc	Rte	Account Name	Home Phone	0 to 30	31 to 60	61 to 90	Over 91	Total	--- Last Payment --- Date	Amount
=====										

SELECTION CRITERIA

Minimum Balance:1000.00
A/R Block 1:30
A/R Block 2:60
A/R Block 3:90

Filter:
 (category = 'cf' AND end_date IS NULL)

City of College Park

A / R A G I N G

08/30/2021 08:46:31

Page: 1

Cyc	Rte	Account Name	Home Phone	0 to 30	31 to 60	61 to 90	Over 91	Total	--- Last Payment --- Date	Amount
Cycle:	1									

682.25	329.34	264.78	1010.06	2286.43	02/23/2021	695.02
--------	--------	--------	---------	---------	------------	--------

1 Subtotals for Cycle 001

682.25 329.34 264.78 1010.06 2286.43

Cycle: 8

212.90	482.91	244.80	490.47	1431.08	04/27/2021	300.00	T
944.12	622.68	129.22	0.00	1696.02	07/26/2021	500.00	O
650.33	345.58	372.75	187.97	1556.63	08/02/2021	300.00	
214.96	233.79	227.01	506.76	1182.52	06/01/2021	500.00	T
791.08	274.97	86.93	0.00	1152.98	07/26/2021	400.00	T
5068.77	1567.06	0.00	0.00	6635.83			O
245.20	267.00	233.66	2371.99	3117.85	04/08/2021	400.00	
301.45	129.79	97.15	700.53	1228.92	08/02/2021	200.00	T
140.72	102.56	161.56	1054.94	1459.78	07/02/2021	125.00	T

9 Subtotals for Cycle 008

8569.53 4026.34 1553.08 5312.66 19461.61

Cycle: 15

602.05	189.84	118.09	1159.07	2069.05	04/26/2021	60.00	T
498.91	149.12	105.66	755.92	1509.61	05/25/2021	181.08	T

2 Subtotals for Cycle 015

1100.96 338.96 223.75 1914.99 3578.66

City of College Park

A / R A G I N G

08/30/2021 08:47:26

Page: 2

Cyc	Rte	Account Name	Home Phone	0 to 30	31 to 60	61 to 90	Over 91	Total	--- Last Payment --- Date	Amount
-----	-----	--------------	------------	---------	----------	----------	---------	-------	------------------------------	--------

Cycle: 25

				4716.10	4716.10	4716.10	0.00	14148.30	07/12/2021	4716.10
--	--	--	--	---------	---------	---------	------	----------	------------	---------

1 Subtotals for Cycle 025

				4716.10	4716.10	4716.10	0.00	14148.30		
--	--	--	--	---------	---------	---------	------	----------	--	--

13 Grand Totals

				15068.84	9410.74	6757.71	8237.71	39475.00		
--	--	--	--	----------	---------	---------	---------	----------	--	--

SELECTION CRITERIA

Minimum Balance:1000.00
A/R Block 1:30
A/R Block 2:60
A/R Block 3:90

Filter:
(category = 'RF' AND end_date IS NULL)

City of College Park

A / R A G I N G

08/30/2021 08:43:03

Page: 1

Cyc	Rte	Account Name	Home Phone	0 to	30	31 to	60	61 to	90	Over	91	Total	--- Last Payment --- Date	Amount
-----	-----	--------------	------------	------	----	-------	----	-------	----	------	----	-------	------------------------------	--------

Cycle: 8

0 Subtotals for Cycle 008				0.00		0.00		0.00		0.00		0.00		
---------------------------	--	--	--	------	--	------	--	------	--	------	--	------	--	--

Cycle: 15

				1000.82		526.87		354.36		401.59		2283.64		
--	--	--	--	---------	--	--------	--	--------	--	--------	--	---------	--	--

1 Subtotals for Cycle 015				1000.82		526.87		354.36		401.59		2283.64		
---------------------------	--	--	--	---------	--	--------	--	--------	--	--------	--	---------	--	--

1 Grand Totals				1000.82		526.87		354.36		401.59		2283.64		
----------------	--	--	--	---------	--	--------	--	--------	--	--------	--	---------	--	--

SELECTION CRITERIA

Minimum Balance:1000.00
A/R Block 1:30
A/R Block 2:60
A/R Block 3:

90

Filter:
(category = 'CC' AND end_date IS NULL)

City of College Park

A / R A G I N G

08/30/2021 08:49:08

Page: 1

Cyc	Rte	Account Name	Home Phone	0 to 30	31 to 60	61 to 90	Over 91	Total	--- Last Payment --- Date	Amount
-----	-----	--------------	------------	---------	----------	----------	---------	-------	------------------------------	--------

Cycle: 8

0 Subtotals for Cycle 008

0.00	0.00	0.00	0.00	0.00
------	------	------	------	------

0 Grand Totals

0.00	0.00	0.00	0.00
------	------	------	------

SELECTION CRITERIA

Minimum Balance:1000.00
A/R Block 1:30
A/R Block 2:60
A/R Block 3:90

Filter:
 (category = 'RC' AND end_date IS NULL)

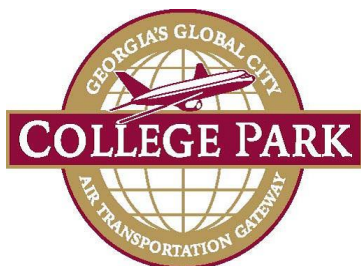

CITY OF COLLEGE PARK

P.O. BOX 87137 · COLLEGE PARK, GA 30337 · 404.767.1537

REG SESSION AGENDA REQUEST

DOC ID: 9068

DATE: September 1, 2021

TO: The Honorable Mayor and Members of City Council

THROUGH: Mercedes Miller, Interim City Manager

FROM: Althea Philord-Bradley, Director of Finance & Accounting

RE: College Park Utility Assistant Grant Program Update

As of August 31, 2021, the overall progress status of the College Park CARES Utility Assistance Grant is as follows:

I. Overview of the College Park CARES Utility Assistance Grant (Includes Phase 1 & Phase 2)

Total Amount of the Utility Assistance Grant Awarded To-Date: \$339,294.20

- **Overall (Phase1 + Phase2) Approved to-date:** 270
- **Overall Denied Applications to-date:** 252
- **Overall Number of Applications Received including Customer Service Referrals as of August 31, 2021:** **626**

II. Customer Service Referred Applicants

Since January 14, 2021, 69 customer service referred applicants have applied for the Utility Assistance Grant and received a 2-week temporary reconnection of services while their application was being processed. This program will continue through the duration of the utility assistance grant application process.

Of the 69 participants assisted:

- 22 customers were existing applicants
- 47 were new applicants
- 44 applicants have been approved to date; 8 could not meet eligibility requirements; 6 did not attend scheduled appointments to complete an application and submit documents. 9 New applicants are pending their application appointments.

III. College Park CARES Utility Assistance Grant- Phase II

The application process reopened for Phase II on April 9, 2021 and originally closed on May 21, 2021. However, that deadline was extended until all CDBG-CV CARES funds are dispersed.

Number of Phase II <u>New</u> Applications received:	224
Number of Phase I applications transferred to Phase II:	22
Total number =	246

Total Number of Phase II Approved:	94
Total Number of Phase II Denied:	47
Total Number of Phase II Pending Appointments:	104

IV. Guidelines & Procedure to Apply for Phase II College Park CARES Utility Assistance Grant

Please Note: In an effort to stay in compliance and avoid duplicitous awarding of funds, utility customers who have already received the utility assistance grant, may only apply once. Please also be aware that previously denied applicants also may not re-apply.

During this 2nd phase of the College Park CARES Utility Assistance Grant, eligible Fulton County customers who have incurred a job loss, income loss or other hardships due to COVID-19, are asked to complete an application and submit required documents via in-person appointments only. Customers should request an appointment by submitting the *Utility Assistance Customer Contact Form*. Please note, the online application is no longer available. Applicants with any impairments are asked to bring a representative to assist them with the application process. *Customers can expect to wait up to 7 business days for a final decision on their application.*

Step one: The customer must complete a **Utility Assistance Grant Customer Contact Form** and submit it to the Receptionist desk.

Step two: Applicant will be contacted within 3 to 5 business days by grant coordinator or grant administrator via phone to schedule an appointment. Applicant will receive a detailed confirmation email following the call.

The required verification documents are as follows:

- Recent Bank Statement
- Recent Utility Bill
- Income Verification Documents
- State of Georgia Identification (with same address on the utility account) .

- Self-Certification of Income
- Third Party Authorization and Waiver of Confidentiality
- Completed Application with COVID-19 Hardship Statement

V. Ineligibility

The following are examples of customers who are **ineligible** to apply or re-apply:

- Previously awarded utility customers (applicants limited to a one-time award)
- Previous applicants denied and did not meet the eligibility requirements
- City of College Park employees
- All Clayton County residents
- Customers who are not the accountholder
- Customers have an inactive/closed utility account with a past due balance
- Customers who no longer have residency within The City of College Park & Fulton County.
- Customers with no qualifying hardship caused directly by the COVID-19 Pandemic.
- Applicants who have received other utility assistance grants from other sources for same the period of time.

There is truly a need for utility assistance in Clayton County, however as you all are aware we have not received CARES funds from Clayton County and are still unable to assist the residence who reside there. Below are the common Clayton County addresses from which we mostly receive Inquiries to apply for Utility Assistance:

- **Poplar Pointe Drive**
- **1951 South Hampton Road**
- **Hanover Street**
- **Sheldon Court**
- **Broad River Road**

VI. SSI Applicants - COVID 19 HARDSHIP STATEMENTS

On May 5, 2021, we received confirmation, from Karen Parish-Fulton County legal counsel, permitting us to assist new applicants who receive SSI as their only source of income. Qualifying applicants may submit their current Social Security Award Letters as an income verification document. They must provide a valid COVID-19 Hardship Statement. Their COVID-19 Hardship Statement would not necessarily speak to job loss or reduced wages/hours but must explain other hardships such as how the COVID-19 pandemic has caused them financial hardship. For example, one might explain how incurring additional expenses for

services, supplies, deliveries, transportation, etc. not normally needed or used prior to the onset of the COVID-19 pandemic has caused a financial strain.

ATTACHMENTS:

- Grant Progress Memo August 31 2021 (PDF)

Review:

- Althea Philord-Bradley Completed 09/01/2021 11:16 AM
- Rosylne Robinson Completed 09/01/2021 12:02 PM
- Jackson Myers Completed 09/01/2021 1:08 PM
- Mercedes Miller Pending
- Mayor & City Council Pending 09/07/2021 7:30 PM



CITY OF COLLEGE PARK

P.O. BOX 87137 • COLLEGE PARK, GA. 30337 • 404/767-1537

August 31, 2021

MEMORANDUM

To: Althea P. Bradley, Director, Finance

From: Donnea N. Anderson, Grant Administrator, College Park CARES Utility Assistance

RE: College Park CARES Utility Assistance Grant Progress Status as of 8/31/2021

As of August 31, 2021, the overall progress status of the College Park CARES Utility Assistance Grant is as follows:

I. Overview of the College Park CARES Utility Assistance Grant
(Includes Phase 1 & Phase 2)

Total Amount of the Utility Assistance Grant Awarded To-Date:	\$339,294.20
--	---------------------

- **Overall (Phase1 + Phase2) Approved to-date:** 270
- **Overall Denied Applications to-date:** 252
- **Overall Number of Applications Received including Customer Service Referrals as of August 31, 2021:** **626**

II. Customer Service Referred Applicants

Since January 14, 2021, 69 customer service referred applicants have applied for the Utility Assistance Grant and received a 2-week temporary reconnection of services while their application was being processed. This program will continue through the duration of the utility assistance grant application process.

Of the 69 participants assisted:

- 22 customers were existing applicants
- 47 were new applicants
- 44 applicants have been approved to date; 8 could not meet eligibility requirements; 6 did not attend scheduled appointments to complete an application and submit documents. 9 New applicants are pending their application appointments.

III. College Park CARES Utility Assistance Grant- Phase II

The application process reopened for Phase II on April 9, 2021 and originally closed on May 21, 2021. However, that deadline was extended until all CDBG-CV CARES funds are dispersed.

Number of Phase II <u>New</u> Applications received:	224
Number of Phase I applications transferred to Phase II:	22
Total number =	246
<hr/>	
Total Number of Phase II Approved:	94
Total Number of Phase II Denied:	47
Total Number of Phase II Pending Appointments:	104

IV. Guidelines & Procedure to Apply for Phase II College Park CARES Utility Assistance Grant

Please Note: In an effort to stay in compliance and avoid duplicitous awarding of funds, utility customers who have already received the utility assistance grant, may only apply once. Please also be aware that previously denied applicants also may not re-apply.

During this 2nd phase of the College Park CARES Utility Assistance Grant, eligible Fulton County customers who have incurred a job loss, income loss or other hardships due to COVID-19, are asked to complete an application and submit required documents via in-person appointments only. Customers should request an appointment by submitting the *Utility Assistance Customer Contact Form*. Please note, the online application is no longer available. Applicants with any impairments are asked to bring a representative to assist them with the application process. *Customers can expect to wait up to 7 business days for a final decision on their application.*

Step one: The customer must complete a **Utility Assistance Grant Customer Contact Form** and submit it to the Receptionist desk.

Step two: Applicant will be contacted within 3 to 5 business days by grant coordinator or grant administrator via phone to schedule an appointment. Applicant will receive a detailed confirmation email following the call.

The required verification documents are as follows:

- Recent Bank Statement
- Recent Utility Bill
- Income Verification Documents
- State of Georgia Identification (with same address on the utility account) .
- Self-Certification of Income
- Third Party Authorization and Waiver of Confidentiality
- Completed Application with COVID-19 Hardship Statement

V. Ineligibility

The following are examples of customers who are **ineligible** to apply or re-apply:

- Previously awarded utility customers (applicants limited to a one-time award)
- Previous applicants denied and did not meet the eligibility requirements
- City of College Park employees
- All Clayton County residents
- Customers who are not the accountholder
- Customers have an inactive/closed utility account with a past due balance
- Customers who no longer have residency within The City of College Park & Fulton County.
- Customers with no qualifying hardship caused directly by the COVID-19 Pandemic.
- Applicants who have received other utility assistance grants from other sources for same the period of time.

There is truly a need for utility assistance in Clayton County, however as you all are aware we have not received CARES funds from Clayton County and are still unable to assist the residence who reside there. Below are the common Clayton County addresses from which we mostly receive Inquiries to apply for Utility Assistance:

- **Poplar Pointe Drive**
- **1951 South Hampton Road**
- **Hanover Street**
- **Sheldon Court**
- **Broad River Road**

VI. SSI Applicants – COVID 19 HARDSHIP STATEMENTS

On May 5, 2021, we received confirmation, from Karen Parish-Fulton County legal counsel, permitting us to assist new applicants who receive SSI as their only source of income. Qualifying applicants may submit their current Social Security Award Letters as an income verification document. They must provide a valid COVID-19 Hardship Statement. Their COVID-19 Hardship Statement would not necessarily speak to job loss or reduced wages/hours but must explain other hardships such as how the COVID-19 pandemic has caused them financial hardship. For example, one might explain how incurring additional expenses for services, supplies, deliveries, transportation, etc. not normally needed or used prior to the onset of the COVID-19 pandemic has caused a financial strain.



CITY OF COLLEGE PARK

P.O. BOX 87137 · COLLEGE PARK, GA 30337 · 404.767.1537

REG SESSION AGENDA REQUEST

DOC ID: 9048

DATE: September 1, 2021

TO: The Honorable Mayor and Members of City Council

THROUGH: Mercedes Miller, Interim City Manager

FROM: Michelle Johnson, Director of Recreation & Cultural Arts

RE: College Park Football Spirit Parade

PURPOSE: To seek approval for a parade for Homecoming for the Rams football and cheerleading program on Saturday, October 16, 2021.

REASON: To seek approval for the parade for Homecoming for the Ram's football and cheerleading program on Saturday, October 16, 2021.

RECOMMENDATION: To approve the College Park Football Spirit parade for the Ram's football and cheerleading program on October 16, 2021.

BACKGROUND: The Recreation Leaders would like to promote the start of homecoming for the Ram's football and cheerleading program with a parade on October 16, 2021. The parade line up and route will start on Auditorium Way behind Conley Recreation Center and go to Princeton Avenue and turn right onto Princeton Avenue to College Street and turn right onto College Street to enter into Bill Badgett Stadium for presentation of teams on the football field. The time for the parade would be around 8:30 AM and should take about 30-45 minutes for the teams to walk the parade route from Auditorium to the stadium. We will work with College Park Police and Fire Department with coordinating closing part of Princeton Avenue from Auditorium Way to College Street and closure from College Street from Princeton Avenue to John Calvin to in front of the Conley Recreation Center to the Hawks Court where the end of the parade will enter onto the track at Badgett Stadium.

YEARS OF SERVICE: N/A

COST TO CITY: N/A

BUDGETED ITEM: N/A

REVENUE TO CITY: N/A

CITY COUNCIL HEARING DATE: September 7, 2021

CONSIDERATION BY OTHER GOVERNMENT ENTITIES: Police and Fire for the approval of the route and assistance with traffic.

AFFECTED AGENCIES: Police and Fire

RELATIONSHIP TO EXISTING ORDINANCE OR RESOLUTION: N/A

REQUIRED CHANGES TO WORK PROGRAMS: N/A

STAFF: Recreation Staff and Recreation Volunteers

ATTACHMENTS:

- HomecomingParadeMap_Oct2021 (PDF)

Review:

- Michelle Johnson Completed 08/30/2021 11:02 AM
- Rosyline Robinson Completed 09/01/2021 12:00 PM
- Wade Elmore Pending
- Thomas Kuzniacki Pending
- Mercedes Miller Completed 09/01/2021 1:39 PM
- Mayor & City Council Pending 09/07/2021 7:30 PM

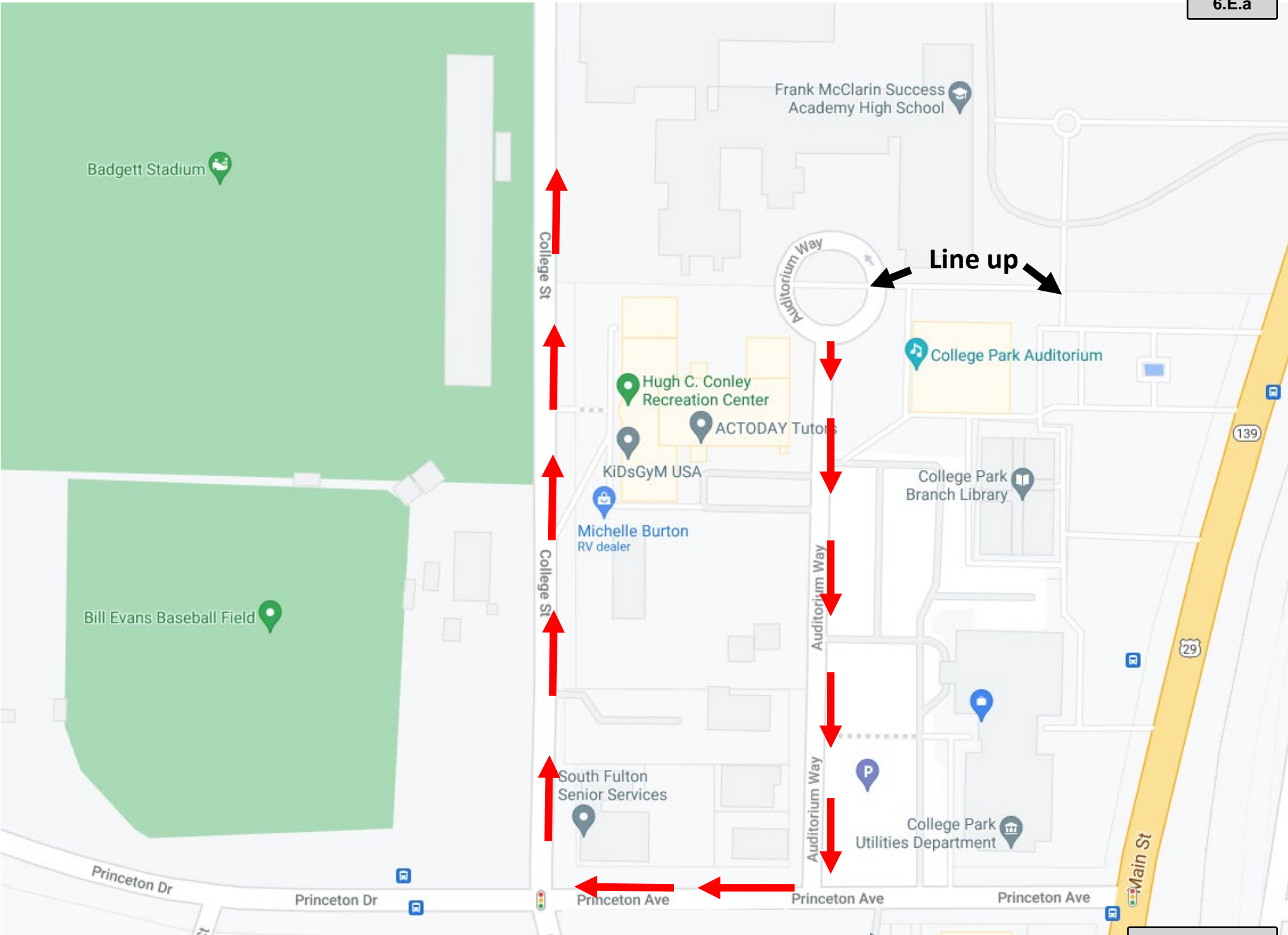

Line up



CITY OF COLLEGE PARK

P.O. BOX 87137 · COLLEGE PARK, GA 30337 · 404.767.1537

REG SESSION AGENDA REQUEST

DOC ID: 8994

DATE: September 1, 2021

TO: The Honorable Mayor and Members of City Council

THROUGH: Mercedes Miller, Interim City Manager

FROM: Shavala Moore, City Clerk

RE: Mardi Gras Birthday Celebration - Special Event

PURPOSE: Consideration of and action on a request from Mignon Phillpotts for approval street usage at Hemphill and Hawthorne Ave. for a Mardi Gras Birthday Celebration.

REASON: Please see attached e-mail and Special Event Form detailing items requiring City Council approval in the following areas:

1. Use of City streets at Hemphill and Hawthorne Avenue for Mardi Gras 2nd Line

RECOMMENDATION: Mayor and City Council consideration of this request.

BACKGROUND:

COST TO CITY: None.

BUDGETED ITEM: N/A.

REVENUE TO CITY: None.

CITY COUNCIL HEARING DATE: August 16, 2021

CONSIDERATION BY OTHER GOVERNMENT ENTITIES: None.

AFFECTED AGENCIES:

RELATIONSHIP TO EXISTING ORDINANCE OR RESOLUTION: None.

REQUIRED CHANGES TO WORK PROGRAMS: None.

STAFF: Public Works
Fire
Police
Office of the City Clerk

ATTACHMENTS:

- Elysium-Mardi Gras Birthday 07272021 SEP Application (PDF)
- Hold Harmless Agreement - Elysium (PDF)
- Elysium Event Center - Proof of Insurance (PDF)

Review:

- Shavala Moore Completed 09/01/2021 9:35 AM
- Rosyline Robinson Completed 09/01/2021 12:09 PM
- Public Works Pending
- Police Pending
- Fire Completed 08/05/2021 1:32 PM
- Mercedes Miller Completed 09/01/2021 1:38 PM
- Mayor & City Council Pending 09/07/2021 7:30 PM

City of College Park | Special Event Form

3667 Main Street
College Park, GA 30337

Organizer Name: Elysium Event Center

Event Title: Sheila's Mardi Gras Ball – Birthday Celebration

Type of Event: Private Birthday Celebration

Event Organizer's Contact Information: Mignon Philpotts, Director, Elysium Event Center

Mailing Address: 1851 Hawthorne Avenue, College Park, GA 30344

E-Mail Address: mignon@elysiumeventcenter.com

Contact Number: 404-996-6335: Office; : Cell

Designated City Staff Member:

Department:

E-Mail Address:

Contact Number:

Event Information: Sheila's Mardi Gras Ball – Mardi Gras 2nd Line with small Band

Date: Saturday, October 17, 2021

Location of the Event: Elysium Event Center- Streets Surrounding the event venue; Hemphill and Hawthorne

Time: Start: 7:00 pm End: 7:30 pm

Anticipated Attendance: 120

Will the City of College Park incur any expenses? No If yes, explain:

Will there be a need for City Staff to work this event (i.e., Police, Fire, Public Works)? No

If yes, list needed staff. Expenses incurred are the responsibility of the Event Organizer.

What responsibilities will the Event Organizer assume? Any clean-up of any party favors or trash (None is anticipated)

Event materials (flyers, banners, signs, agendas, handouts, etc.) will be the responsibility of: Elysium Event Center and Client

City of College Park | Special Event Form

3667 Main Street
College Park, GA 30337

The Event Organizer is requesting that the City be responsible for providing: [Access to Hemphill and Hawthorne Avenue for a Mardi Gras 2nd Line \(on-foot only\)](#)

What methods of advertising will be used? [None, Private Party](#)

City mandated deadlines:

It is the responsibility of the Event Organizer to obtain Special Event Insurance. Please provide a copy of the Certificate of Insurance. [Elysium Event Center can provide a copy of our Insurance Policy](#)

It is the responsibility of the Event Organizer to notify property owners/lease holders and obtain approval to hold the event on their property. Please provide documentation of notification to and subsequent approval from property owners/lease holders. [We are the Property Owner](#)

Please include any other special needs: [N/A](#)

**HOLD HARMLESS AND RELEASE AGREEMENT
REGARDING PARTICIPATION IN ACTIVITIES HELD ON CITY OWNED PROPERTY**

The Undersigned, to the fullest extent permitted by law, agrees to release, discharge, indemnify and hold harmless the City of College Park, its officers, management, employees, agents, representative and members of City Council, of and from any and all claims, actions, demands, damages, loss, and causes of action, including costs and expenses, arising from injury, including death, to any person, or damage to any property arising out of or by virtue of the participation of the Undersigned in activities; **such as yard sales, family reunions, or any other gathering** held on City owned property, except damage caused by the sole negligence of the City of College Park. Indemnification of the City of College Park shall include, but not be limited to, any expenses, including but not limited to attorney fees and court cost, incurred by the City of College Park in the defense of any claim described herein or as a result of any breach by the Undersigned of the terms of this Agreement.

The Undersigned also understands and acknowledges that the terms of this Agreement apply to any and all present or future demands actions, causes of actions, liens of any kinds, costs, expenses, debts, liabilities, judgments, sums of money, damages, or claims of any kind or character that in any way relate to the participation in activities held on City owned property and that Undersigned may have against the City of College Park, as well as its officers, management, employees, agents, representatives and members of the City Council.

This Agreement is executed by the Undersigned for and on behalf of the Undersigned, his or her heirs, administrators, executors, personal representatives, and assigns, and is intended to be a full and complete release of the City from any and all claims that the Undersigned may now or hereafter have against the City arising out of, or in any way connected with, the Authority's presence on or near the Property. Undersigned understands and acknowledges that this Agreement binds Undersigned's heirs, administrators, executors, personal representatives, and assigns to the greatest extent allowed by law.

UNDERSIGNED HAS BECOME FAMILIAR WITH THE TERMS OF THIS FORM. UNDERSIGNED UNDERSTANDS AND AGREES TO ITS CONTENTS. UNDERSIGNED HAS HAD AN OPPORTUNITY TO ASK QUESTIONS AND UNDERSIGNED HAVE BEEN ANSWERED TO UNDERSIGNED'S SATISFACTION.

As evidenced by the below signature, the Undersigned has read and agrees to abide by the above Hold Harmless and Release Agreement.

SIGNED

Mignon C. Philpotts
NAME (Printed)

1851 Hawthorne Avenue, College Park
ADDRESS

404-510-8501
APPLICANT PHONE NUMBER

8-31-2021
DATE

Elysium Event Center
ORGANIZATION NAME

1851 Hawthorne Avenue, College Park GA 30337
ORGANIZATION ADDRESS

Sworn to and subscribed
Before me this 21 day
Of September 20 21

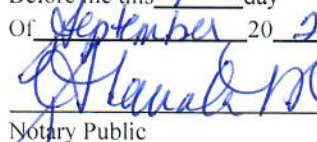
Notary Public



Nature of Activity:
Birthday Celebration, Mardi Gras 2nd-Line
Elysium Event Center on Hawthorne and Hemphill
Location of Event

STOCK COMPANY

COMMERCIAL LINES POLICY



POLICY NUMBER: NPP1502439

Prior Policy Number: NPP1475397

WESTERN WORLD INSURANCE COMPANY TUDOR INSURANCE COMPANY STRATFORD INSURANCE COMPANY

266392

Agent/Broker #07401

COMMON POLICY DECLARATIONS

Named Insured and Mailing Address:

RESTORING THE NEIGHBORHOOD LLC
DBA: ELYSIUM EVENT CENTER

3581 MAIN ST
ATLANTA, GA. 30337

This contract is registered and delivered as a surplus line coverage under the Surplus Line Insurance Law O.C.G.A. Chapter 33-5.

Producer:

SOUTHERN INSURANCE UNDERWRITERS, INC.
P O BOX 105609
ATLANTA, GA 30348-5609

Policy Period: (Mo./Day/Yr.)

From: 07/02/2018

To: 07/02/2019

12:01 AM, standard time at your mailing address shown above.

IN RETURN FOR THE PAYMENT OF THE PREMIUM, AND SUBJECT TO ALL THE TERMS OF THIS POLICY, WE AGREE WITH YOU TO PROVIDE THE INSURANCE AS STATED IN THIS POLICY.

THIS POLICY CONSISTS OF THE FOLLOWING COVERAGES FOR WHICH A PREMIUM IS INDICATED. THIS PREMIUM MAY BE SUBJECT TO ADJUSTMENT.

Commercial Property Coverage Part	\$	3,268.00
Commercial General Liability Coverage Part	\$	1,945.00
Commercial Auto Coverage Part	\$	NOT COVERED
_____	\$	_____
_____	\$	_____
_____	\$	_____
Other Coverages: Terrorism Risk Insurance Act	\$	NOT COVERED
_____	\$	_____
_____	\$	_____
_____	\$	_____
TOTAL ADVANCE PREMIUM	\$	5,213.00
Policy Fee	\$	125.00
Surplus Lines Tax	\$	213.52
_____	\$	_____
_____	\$	_____
_____	\$	_____
_____	\$	_____
GRAND TOTAL	\$	5,551.52

Forms and endorsements applying to this policy and attached at time of issue:

See Applicable Schedule Of Forms And Endorsements No FLAT cancellations.

All Fees are fully earned at inception.



CITY OF COLLEGE PARK

P.O. BOX 87137 · COLLEGE PARK, GA 30337 · 404.767.1537

REG SESSION AGENDA REQUEST

DOC ID: 9052

DATE: September 1, 2021

TO: The Honorable Mayor and Members of City Council

THROUGH: Mercedes Miller, Interim City Manager

FROM: Melissa Echevarria, Director of Public Works

RE: SkyTrain Way and Hospitality Way Road Construction

PURPOSE: To finish the uncompleted construction process needed on both streets -Sky Train Way and Hospitality Way by providing all material needed to bring both sections of roadway up to City Specifications.

REASON: To complete the construction process by installing and removal of material from the construction site to bring both roads up to the required elevation specification by installing curb and gutter, asphalt topping on sky train way and hospitality way Per City streets specifications. The Public Works Division recommends Mullins Brother Paving in the amount of \$219, 500

RECOMMENDATION: Mayor and City Council approve Mullins Brother Paving lowest bidder, in the amount of \$219,500 to provide site to grade, slope and improve elevation at both locations. There is \$133,205 budgeted in FY 2022 to be applied towards the completion of the construction site. The additional \$ 86,295.00 to complete this project will come from TSPLOST funds.

BACKGROUND: On October 19, 2020 Mayor and City Council agreed to complete all unfinished construction work needed on Sky Train Way and Hospitality Way if all information and documents were completed and received or the traffic study on Sky Train Way and Hospitality Way per Mayor and City Council recommendations.

COST TO CITY: \$ 219,500

BUDGETED ITEM: Yes, budgeted in Highways & Streets, \$81,645.00 Account # 100-4200-52-5751 and Stormwater Utility, \$51,560.00 Account# 560-4250-52-5820 T-SPLOST funds maintenance and safety enhancements-resurfacing \$19,674 and quick response projects \$66,621 Account # 235-4962-54-7700

REVENUE TO CITY: None.

CITY COUNCIL HEARING DATE: September 7, 2021

CONSIDERATION BY OTHER GOVERNMENT ENTITIES: No

AFFECTED AGENCIES: None

RELATIONSHIP TO EXISTING ORDINANCE OR RESOLUTION: None

REQUIRED CHANGES TO WORK PROGRAMS: No

STAFF: Highways and Streets

ATTACHMENTS:

- Response from John Selden ATL-DOA Airport GM -- Pavement and curb-gutter for SkyTrain Way and Hospitality Way LTR 113020 (003) (PDF)
- Traffic Study Cover Letter - SkyTrain Way and Hospitality Way - 6th Amendment to 2000 IGA allows 30 days for review by ATL-DOA (PDF)
- Agenda Memo ID #2021-9052 - ITB – SKY TRAIN WAY PAVING PROJECT - 081021 (PDF)
- ITB – SKY TRAIN WAY PAVING PROJECT - Specs (PDF)

Review:

- Melissa Echevarria Completed 08/23/2021 10:12 AM
- Purchasing Completed 08/23/2021 10:29 AM
- Finance Completed 09/01/2021 9:56 AM
- Jackson Myers Completed 08/27/2021 4:01 PM
- Gary Young Completed 09/01/2021 11:55 AM
- City Attorney's Office Completed 09/01/2021 12:24 PM
- Rosyline Robinson Completed 09/01/2021 1:30 PM
- Mercedes Miller Completed 09/01/2021 1:40 PM

- Mayor & City Council Pending 09/07/2021 7:30 PM



Keisha Lance Bottoms
Mayor

John Selden
Airport General Manager

November 30, 2020

VIA EMAIL AND US MAIL

Mr. Gary Young
Director of Airport Affairs
City of College Park, GA
P.O.Box 87137
College Park, GA 30337

Re: SkyTrain Way and Hospitality Way

Dear Mr. Young:

This will acknowledge receipt of your letter dated November 5, 2020, sent in accordance with the Sixth Amendment to the March 2000 IGA, presenting the results of the traffic study of SkyTrain Way and Hospitality Way. The study contained the results, and Councils recommendations regarding the pavement of the remaining sections of the above referenced road ways. Your letter also sets forth a total of four items recommended by College Park's Mayor and Council. First, thank you for completing the study and allowing the Department and other City of Atlanta representatives to provide input to your Consultants. The following will address the four items as presented in your letter.

Item 1. Complete SkyTrain Way with one lane open allowing traffic to flow southward only, from Hospitality Way to the ATL West Parking Deck. In this option, the north bound lane will have gates or bollards with Knoxbox and only open for emergencies. The two lane road will be 26 feet wide, with 30 foot unobstructed path. This will be completed as a fire apparatus access road and shall be capable of supporting an imposed load of 75,000 pounds. This road will have concrete curb and gutter.

Concerns: We have no objections to the road way being completed as described above. As noted the main concern was the ability of the roadway when completed to support fire apparatus. We are satisfied that this accomplishes that requirement. As noted in the study once completed additional measures may be required based upon traffic and perhaps motor vehicle operator behavior. Drivers familiar with the area may attempt to go north on the road and simply wait for traffic to clear headed south bound so that they can have easier access to Camp Creek and I-285. Further, in the study it was stated that a south bound lane would also permit overflow parking in the ATL West parking deck for special events that might take place at the GICC or the Arena. It must be noted that while use of the deck is not intended to be restricted it was constructed for the purpose of replacing the loss of, on airport parking spaces due to the construction of other airport facilities. Therefore, it is possible that parking could be restricted or the parking deck could be used for airport employee parking only in the future.



Item 2. Complete Hospitality Way. Complete Hospitality Way as a two-way, two lane road, with 30 foot unobstructed path, capable of supporting an imposed load of 75,000 pounds. The paved road will have concrete curb and gutters.

Concerns: None

Item 3. Request that DOA allow the proposed new location for Brown Road to connect as a right-turn-only road from SkyTrain Way.

Concerns: This item is not a required issue based on the Sixth amendment to the IGA. As noted in the study this item will require additional study by the engineers, such as reviewing the potential line of sight from the bridge. As further noted in the study this would be a new intersection, and which was not considered by the DOA when the DOA designed and constructed its portion of SkyTrain Way, and locating the entrance to the ATL West Deck. Therefore, DOA is not in position to agree to the request at this time.

Item 4. Request that DOA allow a covered walkway from the site of the proposed Sheraton Hotel to connect to the sidewalk of the ATL West Deck at the wall opening near the deck's central elevator core. (Note: Construction of the covered sidewalk will require a legal agreement between the DOA and the City of College Park.)

Concerns: This item like item three is outside the Sixth Amendment and requires further discussion. As noted an agreement would be required between the DOA and College Park because the covered walkway would cross the College Park section of SkyTrain Way, and then connect to DOA property. DOA has concerns regarding the potential intent to place guests of the hotel into the ATL West deck who are not parking in the deck but simply want to use the facilities of the deck (e.g. elevators, moving sidewalks etc.) to obtain access to the SkyTrain station. This presents liability and cost concerns since those potential users would be charged to the DOA under the present cost allocation formulas for the operation of the SkyTrain. Those issues would have to be addressed before the DOA could agree to this request.

We appreciate the cooperation, and assistance we have received from you, the Mayor, and the City of College Park Council Members as we have developed and constructed the ATL West Deck. We do believe that it fits well into the area and believe that its use will be beneficial to the Airport and the City of College Park. We look forward to further discussions regarding items three and four. Should you have any questions or if I or my staff can be of further assistance please let me know.

Sincerely,



John Selden
Airport General Manager

CC: Carmen Chubb, Chief of Staff, City of Atlanta
Jon Keen, Chief Operating Officer (Interim), City of Atlanta
Bianca Motley Broom, Mayor, City of College Park
Gary Young, Director of Airport Affairs, City of College Park
Terrence R. Moore, ICMA-CM , City Manager, City of College Park
Michael L. Smith, Deputy General Manager, City of Atlanta/DOA
Myrna M. White, Director, Public Affairs, City of Atlanta/DOA
Walter Vinson, Government Affairs Manager, City of Atlanta/DOA



CITY OF COLLEGE PARK

P.O. BOX 87137 • COLLEGE PARK, GA. 30337 • 404/767-1537

November 5, 2020

Mr. John Selden, Airport General Manager
Hartsfield-Jackson Atlanta International Airport
Department of Aviation
6000 North Terminal Parkway, Suite 4000
Atlanta, Georgia 30320

Subject: Pavement of SkyTrain Way and Hospitality Way; Brown Road and a Covered Walkway

Dear Mr. Selden:

Per the terms of the Sixth Amendment to the March 2000 IGA, College Park presents the results of the SkyTrain Way and Hospitality Way traffic study, and the Council's approved recommendations, to the Department of Aviation (DOA). The traffic study, prepared by Croy Engineering, accompanies this letter.

Per the terms of the Sixth Amendment to the 2000 IGA, the DOA will have 30 days from receipt of College Park City Council's recommendation, and the traffic study, to respond with any concerns, or their approval of the roadway completion recommendations.

Does the Department of Aviation approve of Items 1-4 below, as recommended by College Park's Mayor and Council? Please let us know if you have questions or concerns.

Items 1 and 2 refer to the preferred pavement and routing options for SkyTrain Way and Hospitality Way. If you approve of Items 1 and 2, then College Park will proceed with Item 5, the RFP for pavement services. Paving will take place when funds become available.

Items 3 and 4 (below) will require the completion of additional engineering drawings, and legal agreements that must be negotiated. College Park requests your approval to move forward with *discussion* of connecting Brown Road to SkyTrain Way, and *discussion* of a covered walkway across SkyTrain Way to the ATL West Parking Deck.

College Park's staff recommendation, approved by consensus by College Park's Mayor and City Council during their October 19, 2020, Work Session, is as follows:

1. Complete SkyTrain Way as a two lane road, with only one lane open allowing traffic to flow southward only, from Hospitality Way towards the entrance to the ATL West Parking Deck. In this option, the north bound lane will have gates or bollards, with KnoxBox, and only open for emergencies. This two lane road will be a 26' wide paved road, with 30' unobstructed path. This will be completed as a fire apparatus access road,

and shall be capable of supporting an imposed load of 75,000 pounds. The paved road will have concrete curb and gutter.

2. Complete Hospitality Way as a two way, two lane road (26' wide paved road, with 30' unobstructed path, capable of supporting an imposed load of 75,000 pounds). The paved road will have concrete curbs and gutters.
3. Request that the DOA allow the proposed new location for Brown Road to connect as a right-turn-only road from SkyTrain Way. (Note: Relocation of Brown Road will require a legal agreement between the DOA and the City of College Park. Relocation of Brown Road will require a real estate agreement between College Park and the owner of the land for the proposed Brown Road relocation. Engineers must determine whether or not the proposed roadway can be located as proposed due to other intersection proximity concerns.)
4. Request the DOA to allow a covered walkway from the site of the proposed Sheraton Hotel to connect to the sidewalk of the ATL West Parking Deck at the wall opening near the deck's central elevator core. (Note: Construction of the covered sidewalk will require a legal agreement between the DOA and the City of College Park.)
5. If the DOA accepts the recommendations of College Park's Council, then College Park Public Works is authorized to issue an RFP for roadway paving and curb and gutter services.
6. College Park staff is to work with the DOA to make sure that wayfinding signage is installed to help route cars from the ATL West Parking Deck through the CONRAC road system to College Park's Main Street (Roosevelt Highway).

College Park's staff looks forward to continuing to work with the staff of the Department of Aviation as the roadways are paved and adjacent hotels and offices are designed and built.

We look forward to your response.

Sincerely,



Gary Young
 Director of Airport affairs
 City of College Park, GA
 Office: 404-669-9262
 Cell: 404-242-1944

Cc: Terrence R. Moore, ICMA-CM, City Manager
 Honorable Mayor and Council of College Park
 WalterVinson, Manager, Government Affairs, ATL/DOA



CITY OF COLLEGE PARK

PO BOX 87137 • COLLEGE PARK, GA 30337 • (404) 767-1537

AGENDA MEMORANDUM NO. 2021-9052

DATE: AUGUST 23, 2021

TO: OFFICE OF THE CITY MANAGER

FROM: WILLIS MOODY, PURCHASING & FLEET ADMINISTRATOR

SUBJECT: ITB – SKY TRAIN WAY PAVING PROJECT - 081021
SEALED BID OPENING

The purpose of this communication is to secure the approval to purchase the following item(s). Please include the following item(s) on the upcoming Mayor/Council agenda.

Item Description: Sky Train Way Paving Project

Budgeted item(s): Yes

Recommendations: Mullins Brother Paving, is recommended at \$219,500.00 for this project.

Explanation of recommendation in full:

The bid was published on the City of College Park website under the Bids/RFPs location, Vendor Registry.com, DOAS GPR (Georgia Procurement Registry) and the National Association of Minority Contractors - Georgia Chapter. The advertisement was published from July 14, 2021 thru August 10, 2021 at 9:30 am.

1,774 representatives were contacted for this bid on July 14, 2021.

The official Zoom (virtual) bid open was scheduled for Tuesday, August 10, 2021 at 10:00 am with HEH Paving, Mullins Brothers Paving and S.T. English Construction representatives logged into the meeting.

Raymond Cotton was present to represent the City during the bid open.

Join Zoom Meeting

<https://zoom.us/j/99972326887?pwd=ZXZkSzhTU3dpeVEwT29aR0NXU3RHZz09>

Meeting ID: 999 7232 6887 ~ Passcode: 354717



CITY OF COLLEGE PARK

PO BOX 87137 • COLLEGE PARK, GA 30337 • (404) 767-1537

Bid Tabulation

ITB – SKY TRAIN WAY PAVING PROJECT - 081021

	Company Name	Bid Amount (\$)	Identified Minority Class	Located within city limits	Previously worked w/CP
1	Mullins Brothers Paving	\$219,500.00	N	N	Y
2	HEH Paving	\$248,891.47	Y (AABE)	N	Y
3	S.T. English Construction	\$253,412.38	Y (FBE)	N	Y
4					

A “**Minority Business Enterprise**” (MBE) is a business which is an independent and continuing operation for profit, performing a commercially useful function, which is owned and/or controlled by one or more minority group member(s).

- (1) African American Business Enterprise (AABE) (2) Hispanic Business Enterprise (HBE)
 (3) Female Business Enterprise (FBE) (4) Asian Business Enterprise (ABE)
 (5) Native American Business Enterprise (NABE) (6) Minority Veteran (MV)

An “**Owned**” is a minority or female owner which possesses an ownership interest 51% of the business

A “**Controlled**” is a minority or female which possess and exercise the legal authority and power to manage business assets, good will and daily operations of the business and actively and continuously exercise such managerial authority and power in determining the policies and directing the operations of the business.

The original proposal(s) are available for review in the Purchasing Department. Contact Willis Moody, Purchasing & Fleet Administrator (wmoody@collegeparkga.com) to schedule a time.



REQUEST FOR SEALED PROPOSAL

ADVERTISEMENT for CONTRACTUAL SERVICE

ITB – SKY TRAIN WAY PAVING PROJECT - 081021

The City of College Park is accepting **sealed proposals** from qualified vendors for **SKY TRAIN WAY PAVING PROJECT**. Proposals will be received no later than **TUESDAY, AUGUST 10, 2021 at 9:30 am** at the City of College Park Purchasing Department, 3667 Main Street, College Park Georgia, 30337. Proposals received after the above date and time, or in any other location other than the Purchasing Department will not be considered.

A bid packet may be obtained by clicking "related documents" below or a hard copy from the City of College Park Purchasing Department, 3667 Main Street, College Park, Georgia 30337 or www.collegeparkga.com, under the Bids / RFPs section.

Timeline

Q&A and Clarifications (email only to wmoody@collegeparkga.com) Ref: Sky Train Way Paving Project	August 3, 2021	12:00 pm (EST)
Addendum(s) published	August 6, 2021	4:00 pm (EST) Deadline
Open Sealed Bids	August 10, 2021	10:00 am (EST)

Any/all addenda must be signed and dated and made a part of bid packet. It is always the vendor's responsibility to check the City of College Park's website for any/all addenda.

The City of College Park reserves the right to reject any or all bids based on past performance and to waive technicalities and informalities and re-advertise. All Minority, Woman and Small Businesses are strongly encouraged to apply. Only responsive bids that are determined to meet the requirements and criteria set forth by the City of College Park will be considered.



PURPOSE SCOPE OF WORK

GENERAL PURPOSE

The City of College Park is looking for a contractor to complete to provide professional contractual services for the Department of Public Works, Highways and Streets Division to complete paving, grading and drainage improvements at two (2) locations.

Any problems encountered with equipment or materials or labor shall be corrected by the contractor at “NO” additional expense to the City of College Park. The projects shall also be warranted for one (1) year after completion. The City reserves the right to award one or both locations to the most responsive bidder.

SCOPE OF WORK

Contractor agrees to provide all the necessary labor, equipment, and materials in accordance with the Project Details, Drawings and additional specifications as may be needed. The work shall occur within thirty (30) days after receipt by contractor of all necessary permits. Any alteration or deviation from the specifications that involve additional costs will become an extra charge over and above the cost of the original agreement.

All work shall be performed in a good and workmanlike manner per industry standards and shall be in compliance with the specifications.

LOCATIONS

1. Lesley Drive
 - a. Contractor required to provide individual measurement estimate of location,
 - b. Arrange site to grade, slope and improve elevation,
 - c. Install curb and gutter to channel water from site,
 - d. Excavate unsuitable material:
 - i. Approximately 240' x 25'
 - ii. Haul off unsuitable material from site
 - e. Deliver and install approximately 670 SY of GAB approximately 8” deep,
 - f. Adjust all manholes in roadway to grade,
 - g. Deliver and install:
 - i. Approximately 150 TN’s of 19 mm asphalt binder at 4” thick
 - ii. Approximately 75 TN’s of 12.5 mm asphalt topping at 2” thick
 - h. Install thermoplastic striping to include and stop bars, white edge line and double yellow striping,
2. Sky Train Way
 - a. Contractor required to provide individual measurement estimate of location
 - b. Arrange site to grade, slope and improve elevation,
 - c. Install curb and gutter to channel water from site,

- d. Excavate unsuitable material:
 - i. Approximately 565' x 24' SY
 - ii. Haul off from site
- e. Deliver and install approximately 1,510 SY of GAB approximately 8" deep,
- f. Adjust all manholes in roadway to grade,
- g. Deliver and install:
 - i. Approximately 340 TN's of 19 mm asphalt binder at 4" thick
 - ii. Approximately 170 TN's of 12.5 mm asphalt topping at 2" thick
- h. Install thermoplastic striping to include and stop bars, white edge line and double yellow striping,



CITY OF COLLEGE PARK

P.O. BOX 87137 · COLLEGE PARK, GA 30337 · 404.767.1537

REG SESSION AGENDA REQUEST

DOC ID: 8944

DATE: September 1, 2021

TO: The Honorable Mayor and Members of City Council

THROUGH: Mercedes Miller, Interim City Manager

FROM: Hugh Richardson, Power Director

RE: Electric Vehicle Charging Stations for the Global Gateway Arena

PURPOSE: To add another level of service at the Global Gateway Arena by providing electric vehicle (EV) charging stations for customers and clients.

REASON: The GICC and Global Gateway Arena have parking for 2000+ vehicles but there are no EV chargers in place. The electric vehicle ownership and usage are trending upwards and more customers attending events will be driving electric vehicles.

RECOMMENDATION: Approve the purchase and installation of (2) ChargePoint Level 2 dual stations through the Sourcewell Contract award from LilyPad EV.

BACKGROUND: The Power Department installed (2) Level 2 dual chargers in 2015 through the Charge Georgia grant program. Since then, the chargers have been used almost daily. Annual KWH usage is 14,494, about \$362 in market price.

Do we charge the customer for the EV recharges? Not yet. Surveys and information obtained by ECG and the Smart Utility Summit, show that little or no electric utility or City charges the customer for the recharge. This is to promote electric vehicle usage to provide a cleaner environment. However, charging for EV recharges will probably occur in the near future starting around \$1.00 per hour. With the increase of electric vehicles, fees will become more common.

Most utilities do charge for use of a level 3 DC quick charge, but those units are 4x the cost of level 2.
(Typical charging fee = 25 cents per minute.)

The proposed installed units would be exactly the same as the ones located at the Public Safety parking lot.

Charging data at the Public Safety parking lot during the past 12 months:

Sessions: 1689
 Average duration per charge: 2 hours, 7 minutes
 KWH used: 14,494

YEARS OF SERVICE: N/A

COST TO CITY: \$17,019.00

BUDGETED ITEM: Yes, 510-4600-54-7710 Electric Improvements

REVENUE TO CITY: N/A

CITY COUNCIL HEARING DATE: Sept. 7, 2021

CONSIDERATION BY OTHER GOVERNMENT ENTITIES: N/A

AFFECTED AGENCIES: N/A

RELATIONSHIP TO EXISTING ORDINANCE OR RESOLUTION: N/A

REQUIRED CHANGES TO WORK PROGRAMS: N/A

STAFF: Power Department

ATTACHMENTS:

- EV Charging Station Quote (PDF)
- EV Charging Station Specifications (PDF)
- EV Charging Station Location (PDF)
- Southwell Contract Award (PDF)

Review:

- Hugh Richardson Completed 08/24/2021 9:59 AM
- Purchasing Completed 08/24/2021 10:38 AM
- Finance Completed 09/01/2021 11:10 AM
- Rosyline Robinson Completed 09/01/2021 12:14 PM
- Denise Cole Completed 09/01/2021 1:23 PM
- Mercedes Miller Completed 09/01/2021 1:37 PM

- Mayor & City Council Pending 09/07/2021 7:30 PM



REMIT PAYMENTS TO:

Wire/ACH:
LilyPad EV
Bank: United Missouri Bank
Routing# 101000695
Checking# 9871859819

Paper Checks:
LilyPad EV
c/o United Missouri Bank
7109 W 80th St
Overland Park, KS 66204

LilyPad EV
9801 W. 100th Terr
Overland Park, KS 66212
(913) 269-2453
keith.anderson@lilypadev.com
www.lilypadev.com

Quote

ADDRESS

College Park, GA
Hugh Richardson
1886 Harvard Avenue
College Park, GA 30337

SHIP TO

College Park, GA
Hugh Richardson
1886 Harvard Avenue
College Park, GA 30337 US

QUOTE # 2894

DATE 06/21/2021

DESCRIPTION	QTY	EACH	AMOUNT
Note Note: Sourcewell ID# 38621	1	0.00	0.00
ChargePoint:CT4021-GW1 Dual Output Gateway Option USA, Bollard Unit - 208/240V @30A with Cord Management	2	5,696.00	11,392.00
ChargePoint:CPCLD-COMMERCIAL-1 1yr Prepaid Commercial Cloud Plan. Prepaid Commercial Cloud Plan subscription with station management features such as: Custom Video uploads and Automatic Software Updates, driver and fleet management features including: Access Control and Pricing & Automatic Payment Collection, as well as energy and power management features which include Power Sharing. Real-time dashboards and reports provided for applicable features. Station Activation purchase required. Cloud Plans are priced per port.	4	329.00	1,316.00
ChargePoint:CT4001-CCM CT4000 Bollard Concrete Mounting Kit. Bolts: 5/8 - 11 x 9 F1554 Grade 55 hot-dipped galvanized threaded bolts - 3 ea. Nuts: 5/8 - Heavy Galvanized Hex Nuts (DH Rated) - 12 ea. Washers: Galvanized Washers (ASTM F436) - 9 ea. Plastic Template - 1 ea	2	86.00	172.00
ChargePoint:CT4000-ASSURE1 1 prepaid year of ChargePoint Assure for CT4000 station. Includes Parts and Labor Warranty, Remote Technical Support, On-Site Repairs when needed, Unlimited Configuration Changes, and Reporting. Priced per station. Requires successful site validation.	2	666.00	1,332.00
ChargePoint:CPSUPPORT-SITEVALID Customer works with their own contractor to perform the construction and station installation. On-site validation used to validate the installation has been performed per ChargePoint published requirements. The on-site validation consists of checking electrical capacity, transformers, panels, breakers, wiring, cellular coverage, and that the station installation meets all ChargePoint published requirements and local codes. A site is defined as a group of stations	1	569.00	569.00

Thank you for your business.

Packet Pg. 96

DESCRIPTION	QTY	EACH	AMOUNT
that are installed within 150 feet of each other. A successful Site Validation is a prerequisite to purchase ChargePoint Assure. CPSUPPORT-SITEVALID is priced for up to 5 stations that exist within the same 150 feet group of stations.			
ChargePoint:CPSUPPORT-ACTIVE Initial Station Activation & Configuration Service includes activation of cloud services and configuration of radio groups, custom groups, connections, access control, visibility control, pricing, reports and alerts. One time initial service per station.	2	332.00	664.00
Note Note: Due to a Global Supply Chain Crisis that is affecting electronic, plastics, and components, suppliers are struggling to meet commitments resulting in increased costs across the board. Ocean and air freight channels are overloaded resulting in worldwide costs for hundreds of piece parts. Therefore, beginning on August 6th 2021 ChargePoint will be imposing a temporary Logistics fee that will have a seamless transition into and out of this crisis while not raising the prices of the equipment.	2	577.00	1,154.00
Sales Tax Sales Tax calculated by AvaTax on Fri 06 Aug 14:19:00 UTC 2021	1	0.00	0.00

STANDARD TERMS & CONDITIONS:

- Quote good for 30 days
- Payment Terms: Net 30
- Manufacturer standard warranty applies
- Standard Lead-time: 30-60 days
- Shipping: FOB Origin, Freight Prepaid & Charged Back
- Customer responsible to verify AT&T/Verizon 4G cell coverage of -85dbm or better at installation location. -70dbm is better than -85dbm.
- Returns of unopened packages subject to restocking charges. Opened packages may not be returned.
- If installation included inquote, we reserve the right to invoice you for the charging station products at delivery and for installation when complete.
- Any Installation costs do not include unforeseen rock or other obstacles found while trenching or boring

SUBTOTAL	16,599.00
TAX (0%)	0.00
SHIPPING	420.00
TOTAL	\$17,019.00

PAYMENT INSTRUCTIONS
for entry into your accounting system

Send Wire or ACH payments to:
LilyPad EV
Bank: United Missouri Bank
Routing# 101000695
Checking# 9871859819

-or-
Send Payment Check to
LilyPad EV
c/o UMB Bank
7109 W 80th St
Overland Park, KS 66204

Accepted By

Accepted Date

CT4000 Family

ChargePoint® Charging Stations

The CT4000 is the latest generation of ChargePoint charging stations. Refined yet rugged, the CT4000 family sets the industry standard for functionality and aesthetics. A robust cord retraction system comes standard on all CT4000 models to eliminate unsightly cords on the ground, and to keep your drivers from having to touch charging cables.

The CT4000 full motion color LCD display instructs drivers while supporting dynamic updates of custom branded videos and advertisements.

The intelligent power sharing feature of the CT4000 doubles the number of parking spaces served by allowing two charging ports to share a single circuit. Sites with single port EV stations can upgrade to dual port stations without requiring additional electrical services.

All CT4000 models offer one or two standard SAE J1772™ Level 2 charging ports with locking holsters, each port supplying up to 7.2kW.

Available in bollard and wall mount configurations, the CT4000 supports easy installation anywhere. To future proof your investment, all stations are fully software upgradeable over the air. All ChargePoint stations are networked and managed through ChargePoint Service Plans¹ and backed by ChargePoint's world class 24/7 driver phone support.

Corporate Branding and Video Advertising

- + Download full motion color videos to your stations²
- + Custom replaceable signage to project your brand
- + Custom "cap" printing available³

Clean Cord Technology™

- + Maintenance-free, light-weight, self-retracting cords come standard on all models
- + Keep charging cords off the ground and out of your and drivers' hands
- + Flexible over entire -22°F to +122°F product temperature range

Intelligent Power Sharing (patent pending)

- + Reduced installation and operating costs
- + Dynamically share one 40A circuit between two parking spaces
- + Double the number of parking spaces for a given site's power capacity
- + Upgrade a single port station to dual port with no electrical upgrade

Driver Friendly User interface

- + Instructional video shows how to use the station
- + Multi-language: English, French, Spanish
- + Touch button interface; works in rain, ice and with gloves
- + Backed by ChargePoint's world class 24/7 driver phone support

Energy Measurement and Management

- + Real-time energy measurement
- + 15 minute interval recording
- + Time of Day (TOD) pricing
- + Load shed by % of running average or to fixed power output

The standard *EV Charging Only* sign is easily replaceable with your branding.

The cap of the CT4000 family is also available for custom branding.

The 5.7" LCD display provides full motion charging instructions in a clear and simple format. It also allows station owners to deliver advertising messaging.

Driver interaction is supported in any weather by five rugged, back-lit buttons with audio feedback.



¹ ChargePoint Service Plans are sold separately

² Download fees apply

³ Minimum order quantities apply

CT4021 Bollard

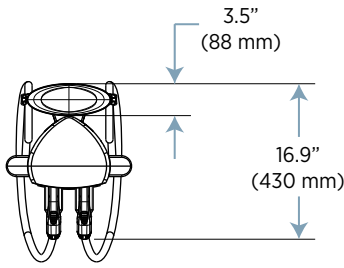

CT4023 Wall Mount

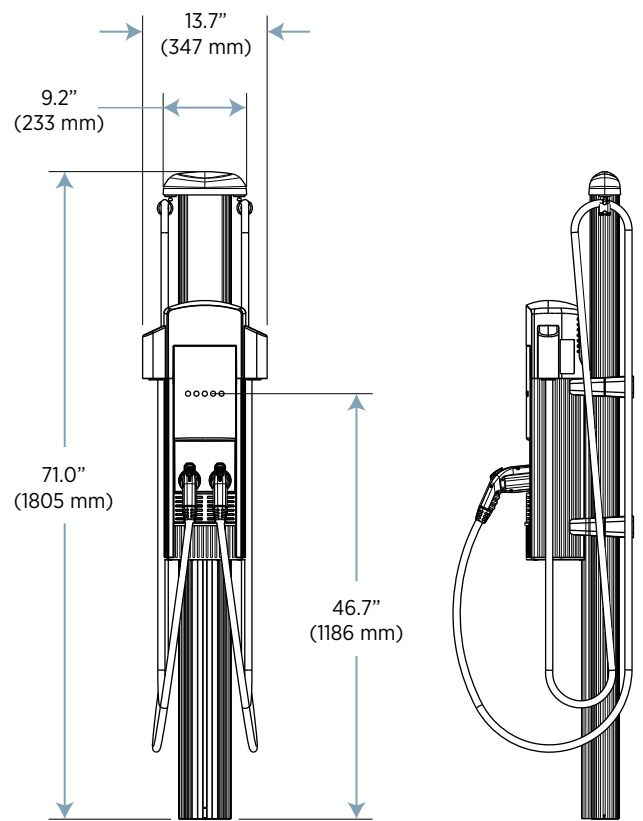
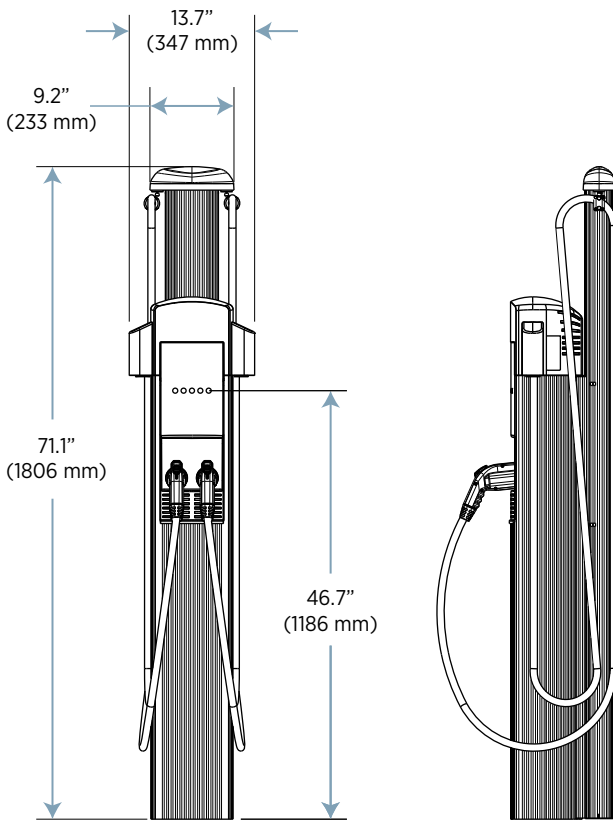
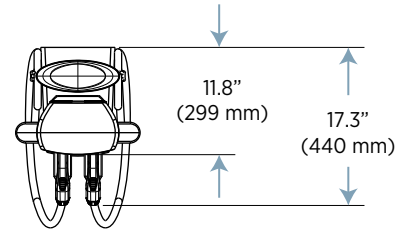

CT4000 Family Specifications

Electrical Input	Single Port	Dual Port
AC Power Input Rating – Standard	208/240VAC 60Hz single phase @ 30A	208/240VAC 60Hz single phase @ 30 x 2
AC Power Input Rating – Power Sharing	n/a	208/240 VAC 60Hz single phase @ 32A
Input Power Connections – Standard	One 40A branch circuit	Two independent 40A branch circuits
Input Power Connections – Power Sharing	n/a	One 40A branch circuit
Required Service Panel Breaker – Standard	40A dual pole (non-GFCI type)	40A dual pole (non-GFCI type) x 2
Required Service Panel Breaker – Power Sharing	n/a	40A dual pole (non-GFCI type)
Service Panel GFCI	Do not provide external GFCI as it may conflict with internal GFCI (CCID)	
Wiring – Standard	3-wire (L1, L2, Earth)	5-wire (L1, L1, L2, L2, Earth)
Wiring – Power Sharing	n/a	3-wire (L1, L2, Earth)
Station Power	8W typical (standby), 15W maximum (operation)	

Electrical Output

AC - Standard	7.2kW (240VAC @ 30A)	7.2kW (240VAC @ 30A) x 2
AC - Power Sharing	n/a	7.2kW (240VAC @ 30A) x 1 OR 3.8kW (240VAC @ 16A) x 2

Functional Interfaces

Connector(s) Type	SAE J1772™	SAE J1772™ x 2
Charging Cable Length	18' (5.5 meters)	18' (5.5 meters) x 2
Overhead Cable Management System	Yes	
LCD Display	5.7" full color, 640x480, 30fps full motion video, active matrix, UV protected	
Card Reader	ISO 15693, 14443, NFC	
Locking Holster	Yes	Yes x 2

Safety and Connectivity Features

Ground Fault Detection	20mA CCID with auto retry
Open Safety Ground Detection	Continuously monitors presence of safety (green wire) ground connection
Plug-Out Detection	Power terminated per SAE J1772™ specifications
Power Measurement Accuracy	+/- 2% from 2% to full scale (32A)
Power Report/Store Interval	15 minute, aligned to hour
Local Area Network	2.4 GHz Wi-Fi (802.11 b/g/n)
Wide Area Network	3G GSM, 3G CDMA

Safety and Operational Ratings

Enclosure Rating	Type 3R per UL 50E
Safety Compliance	UL listed for USA and cUL certified for Canada; complies with UL 2594, UL 2231-1, UL 2231-2, and NEC Article 625
Surge Protection	6kV @ 3000A. In geographic areas subject to frequent thunder storms, supplemental surge protection at the service panel is recommended.
EMC Compliance	FCC Part 15 Class A
Operating Temperature	-22°F to 122°F (-30°C to +50°C)
Operating Humidity	up to 85% @ +50°C (122°F) non-condensing
Non-Operating Humidity	up to 95% @ +50°C (122°F) non-condensing
Terminal Block Temperature Rating	221°F (105°C)
Maximum Charging Stations per 802.11 Radio Group	10. Each station must be located within 150 feet "line of sight" of a gateway station.

ChargePoint, Inc. reserves the right to alter product offerings and specifications at any time without notice, and is not responsible for typographical or graphical errors that may appear in this document.

CT4021 Bollard charging station



Ordering Information

Specify model number followed by the applicable code(s).

Option		Order Code
Model	Single Port Bollard Mount	CT4011
	Dual Port Bollard Mount	CT4021
	Single Port Wall Mount	CT4013
	Dual Port Wall Mount	CT4023
Options	Integral Gateway Modem - USA	-GW1
	Integral Gateway Modem - Canada	-GW2
Warranty	Single Port Extended Hardware-Only Warranty - 2, 3, 4 or 5 year term	CT4010-EXWn*
	Dual Port Extended Hardware-Only Warranty - 2, 3, 4 or 5 year term	CT4020-EXWn*

* Where n is the total number of years in the term

Order Code Examples

If ordering this	the order code is
Dual Port Bollard Mount USA Gateway Station	CT4021-GW1
Single Port Wall Mount Station with 5 Year Warranty	CT4013 CT4010-EXW5
Dual Port Wall Mount Canada Gateway Station with 2 Year Warranty	CT4023-GW2 CT4020-EXW2

CT4023 Wall Mount charging station



For More Information

Visit chargepoint.com

Follow us on Twitter [@chargepointnet](https://twitter.com/chargepointnet)

Like us on Facebook [@chargepoint](https://www.facebook.com/chargepoint)



ChargePoint, Inc.
1692 Dell Avenue | Campbell, CA | 95008-6901 USA
+1.408.370.3802 or toll free 877.370.3802
chargepoint.com

Copyright © 2013 ChargePoint, Inc. All rights reserved. CHARGEPOINT is a U.S. registered trademark/service mark, and an EU registered logo mark of ChargePoint, Inc. All other products or services mentioned are the trademarks, service marks, registered trademarks or registered service marks of their respective owners. PN 73-001020-01 Rev 4

Printed on paper made with 100% post-consumer fiber and 100% certified renewable energy, and processed chlorine free.



Listed by Underwriters Laboratories Inc.



FORM E
CONTRACT ACCEPTANCE AND AWARD



Reviewed by Legal
Signature: *[Handwritten Signature]*
Date: 8-22-17

(Top portion of this form will be completed by NJPA if the vendor is awarded a contract. The vendor should complete the vendor authorized signatures as part of the RFP response.)

NJPA Contract #: 051017-CPI

Proposer's full legal name: ChargePoint, Inc.

Based on NJPA's evaluation of your proposal, you have been awarded a contract. As an awarded vendor, you agree to provide the products and services contained in your proposal and to meet all of the terms and conditions set forth in this RFP, in any amendments to this RFP, and in any exceptions that are accepted by NJPA.

The effective date of the Contract will be July 25, 2017 and will expire on July 25, 2021 (no later than the later of four years from the expiration date of the currently awarded contract or four years from the date that the NJPA Chief Procurement Officer awards the Contract). This Contract may be extended for a fifth year at NJPA's discretion.

NJPA Authorized Signatures:

[Handwritten Signature]

NJPA DIRECTOR OF COOPERATIVE CONTRACTS
AND PROCUREMENT/CPO SIGNATURE

Jeremy Schwartz
(NAME PRINTED OR TYPED)

[Handwritten Signature]

NJPA EXECUTIVE DIRECTOR/CEO SIGNATURE

Chad Coauette
(NAME PRINTED OR TYPED)

Awarded on July 24, 2017

NJPA Contract # 051017-CPI

Vendor Authorized Signatures:

The Vendor hereby accepts this Contract award, including all accepted exceptions and amendments.

Vendor Name ChargePoint, Inc.

Authorized Signatory's Title VP Finance

[Handwritten Signature]

VENDOR AUTHORIZED SIGNATURE

Dave Adams
(NAME PRINTED OR TYPED)

Executed on Aug 22, 2017

NJPA Contract # 051017-CPI

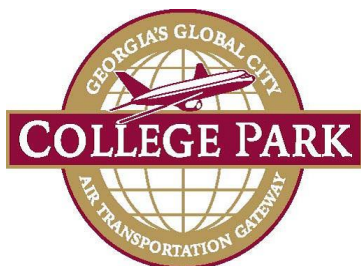

CITY OF COLLEGE PARK

P.O. BOX 87137 · COLLEGE PARK, GA 30337 · 404.767.1537

REG SESSION AGENDA REQUEST

DOC ID: 9064

DATE: September 1, 2021

TO: The Honorable Mayor and Members of City Council

THROUGH: Mercedes Miller, Interim City Manager

FROM: Michelle Johnson, Director of Recreation & Cultural Arts

RE: Approval of College Park Recreation for Emergency Evacuation

PURPOSE: To approve the College Park Recreation Department facility at Conley Center and the City Auditorium as the emergency evacuation for College Park Elementary School. Request to come from Robert Jackson, Dean of Student for College Park Elementary School for Fulton County Schools

REASON: To approve the request for College Park Elementary to use the College Park Recreation Center, Hugh C. Conley and the Auditorium, as a emergency evacuation facility. The first evacuation facility for College Park Elementary School is McClarin High School. The College Park Recreation Center would be a back up to the back up.

City Attorney Note: The proposed agreement requires the Principal to notify their Risk Management Department in the event any damages are caused to the alternative facility; however, the agreement doesn't require the School to indemnify the City. We recommend an indemnification provision.

RECOMMENDATION: To approve the request for the College Park Recreation Center to be a evacuation facility for College Park Elementary School, subject to the School agreeing to indemnify the City.

BACKGROUND:

YEARS OF SERVICE: N/A

COST TO CITY: N/A

BUDGETED ITEM: N/A

REVENUE TO CITY: N/A

CITY COUNCIL HEARING DATE: September 7, 2021

CONSIDERATION BY OTHER GOVERNMENT ENTITIES: Police and Fire

AFFECTED AGENCIES: Recreation, Police and Fire Department

RELATIONSHIP TO EXISTING ORDINANCE OR RESOLUTION: N/A

REQUIRED CHANGES TO WORK PROGRAMS: Accommodate emergency needs for the students at College Park Elementary School by providing shelter which would need staff to open facility to meet their needs.

STAFF: Current staff on hand during need.

ATTACHMENTS:

- Document_2021-08-24_102403 (002) (PDF)

Review:

- Michelle Johnson Completed 09/01/2021 1:25 PM
- Rosyline Robinson Completed 09/01/2021 1:28 PM
- City Attorney's Office Completed 09/01/2021 3:03 PM
- Wade Elmore Pending
- Mercedes Miller Completed 09/01/2021 3:34 PM
- Mayor & City Council Pending 09/07/2021 7:30 PM

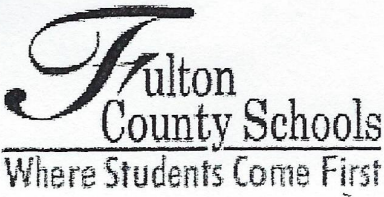

BOARD OF EDUCATION
Julia C. Bernath, President
Kimberly Dove, Vice President
Gail Dean • Linda McCain • Katie Reeves
Katha Stuart • Franchesca Warren
Mike Looney, Ed.D., Superintendent

MEMORANDUM OF UNDERSTANDING

This agreement is made and entered by and between

College Park Elementary School
(School / Facility owned and operated by Fulton County Schools) and

College Park Recreational Center 3717 College Park St.
(Alternate Site Name and Address) College Park, GA 30337

WHEREAS, the alternate site provider is authorized and empowered to enter into leases and building use agreements; and

WHEREAS, if a school should need to evacuate students and staff due to an emergency from one of its buildings or grounds, the school district desires to identify a site where students and staff may be housed until they can be released. Since the alternate site provider could act as a temporary shelter, it is reasonable to set up an agreement outlining the terms; and

WHEREAS, the school desires to enter into an agreement for the emergency only use of the building for students and staff; and

WHEREAS, the alternate site provider understands and agrees that after meeting its responsibilities to its primary usage, it will permit the school to use its physical facilities as an emergency shelter in the event of a disaster;

NOW THEREFORE, in consideration of the mutual covenants and promises contained herein, it is agreed as follows:

- 1. The school shall exercise reasonable care in the use of the alternate facility. Should any supplies be used or damages occur to the physical facility, the Principal should report this information to the Risk Management Department within 24 hours of occurrence.
2. Adequate supervision, as approved by the Principal, will be present.
3. The alternate site provider shall make reasonable efforts to make a building available for emergency shelter use by the school with minimal notice.
4. This agreement shall commence upon the date of execution by both parties. This agreement will remain in force and effect for one year, but may be terminated by either party at any time upon receipt of a thirty day written notice.

WHEREFORE, this Agreement was entered into on the date set forth below and the undersigned, by execution hereof, represent that they are authorized to enter into this agreement on behalf of the respective parties and state that this agreement has been read and each provision is understood. Implementation of this agreement will be in accordance with the emergency operations plan for Fulton County Schools

College Park ES
(School / Facility)

Dr. Maisha Otway
(Principal / Building Administrator)

8/10/2021
(Date)

(Print Name of Alt Site Owner / Rep)

(Principal/Owner/Manager Signature)

(Date)

Emergency Contact Name

Emergency Contact Cell / Phone Number



CITY OF COLLEGE PARK

P.O. BOX 87137 · COLLEGE PARK, GA 30337 · 404.767.1537

REG SESSION AGENDA REQUEST

DOC ID: 9073

DATE: September 1, 2021

TO: The Honorable Mayor and Members of City Council

THROUGH: Mercedes Miller, Interim City Manager

FROM: Shavala Moore, City Clerk

RE: Alcoholic Beverage Violation Appeal - WRAITH

On August 16, 2021, Mayor and Council moved to approve to ratify the City Manager's recommendation to suspend WRAITH's alcohol license for 90-days and pay a civil penalty of \$5000 for alcohol violations that occurred on July 11, 2020, July 13, 2020 and November 15, 2020.

On December July 11, 2020, July 13, 2020 and November 15, 2020, College Park Investigators entered the place of business located at 5021 Old National Highway. Investigators observed the business maintaining a dive, patrons purchasing alcoholic beverages after normal business hours, and/or disorderly conduct displayed on these occasions.

On August 26, 2021, an appeal letter was received by the City from the owners of WRAITH.

Pursuant to the City Code of Ordinances Section 3-46 (g), appeals from the decision of the city manager may be taken to the mayor and council. All appeals shall be filed, in writing, no later than the tenth day following the city manager's decision. Appeals shall be on the record, with no additional evidence heard; provided the mayor and council may direct the city manager to reopen his hearing for the purpose of investigating issues brought before it.

Here, an administrative hearing was held on July 30, 2021. The appeal letter was received on August 26, 2021, ten days after the mayor and council's decision, not the city manager's decision.

Your direction please.

ATTACHMENTS:

- WRAITH Appeal Letter - 08262021 (PDF)
- WRAITH-Citations (PDF)

- Wraith Suspension_Executed_08172021 (PDF)

Review:

- Shavala Moore Completed 08/27/2021 3:20 PM
- Rosyline Robinson Completed 08/27/2021 4:33 PM
- Police Pending
- City Attorney's Office Completed 09/01/2021 3:10 PM
- Mercedes Miller Completed 09/01/2021 3:35 PM
- Mayor & City Council Pending 09/07/2021 7:30 PM

AUG 26 2021

CITY CLERKS OFFICE



Dear Ms. Miller,

This letter is in response to the letter dated 8/17/2021 from Ms. Shavala Moore, City Clerk that provided notification that Wraith Restaurant and Lounge received a 90-day suspension to sell alcohol. We are asking for reconsideration at this time based on the following:

We have terminated employment and/or promotional agreements that have caused harm to Wraith causing us to receive the multiple citations including the one (1) citation for pouring alcohol after 2:00am, maintaining a live and/or disorderly conduct. These citations were received last year and once this behavior was brought to our attention we immediately terminated those managers, staff, and promoters. We have a completely different team in place and feel that it would be unjust to punish them for the previous staff.

Additionally, this team has more experience in the restaurant industry and will continue to help Wraith the sophisticated environment and elegant food plates that we are known for including our lemon pepper wings, lobster macaroni and cheese, lamb chops and chicken and waffles. We have also established an agreement for the City of College Park Police to ensure that Wraith always operates with business integrity and compliance. Additionally, a new security team was hired to also ensure that we employ with all laws.

We ask that you please consider all the corrective actions that we have taken and consider that this was our first-time receiving citations and would ask that you consider reducing our suspension. We have experienced a drastic decrease in customer patronage and food sales due to our suspension.

If you have any questions or need additional information, please feel free to contact Lance Pugh at _____, Pamila Davis at _____ or Sean Davis at _____.

Thank you,

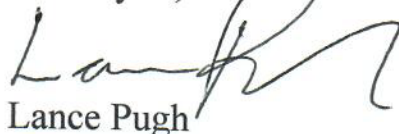

Lance Pugh

COLLEGE PARK MUNICIPAL COURT
COLLEGE PARK MUNICIPAL COURT
3717 COLLEGE ST
COLLEGE PARK, GA 30337

ABSTRACT OF COURT RECORD
STATE OF GEORGIA
FULTON COUNTY
CITY OF COLLEGE PARK

Phone: (404) 761-3131
Fax: (404) 305-2046

Agency Code: **060401J**

ORI:

Incident No. **2011435**

Ticket No: **70771A**

Arrest No.

DL#:

70771A
ANTHONY DEMETRIUS FLOWERS

SSN:

Sex: **MALE**

DOB:

COLLEGE PARK, GA 30349

Race: **BLACK**

Age: **52**

VEHICLE INFORMATION	TAG #:	STATE:	YEAR:
	DESCRIPTION:		

VIOLATION INFORMATION Initial Charge: **ALCOH BEV BUSINESS HRS/DAYS PACK SALES**
Statute:

Convicted Charge: **ALCOH BEV BUSINESS HRS/DAYS PACK SALES**
Statute:

BAC %: **.0**

Speed:

Zone:

Date of Violation: **11/15/2020**

Officer: **SHANIECE DURDEN**

Badge No: **2628**

Complainant:

Date of Judgment: **03/17/2021**

Judgment of Court: **Guilty**

Judge: **MONICA EWING**

Represented by (if any):

Appointed (if any):

Remarks:
210.00

PROBATION:	END DATE:	WITH:
DEFENDANT WAS FINED:		BAIL FORFEITED: <input type="checkbox"/>
FINE AMOUNT \$: 150.40		FINE PAID: <input type="checkbox"/>
PLUS ASSESSMENTS OF \$: 59.60		APPEALED: <input type="checkbox"/>
FOR A TOTAL OF \$: 210.00		SENTENCED TO:
- PAYMENTS \$: 210.00		Years in Jail,
TOTAL \$: 0.00		Months in Jail,
		Days in Jail.



I certify that this is a true and correct copy of my court record.

SIGNED _____

04/30/2021

DOCKET: 70771A

Court Clerk / Deputy Court Clerk

COLLEGE PARK MUNICIPAL COURT
 COLLEGE PARK MUNICIPAL COURT
 3717 COLLEGE ST
 COLLEGE PARK, GA 30337

ABSTRACT OF COURT RECORD
STATE OF GEORGIA
FULTON COUNTY
CITY OF COLLEGE PARK

Phone: (404) 761-3131
 Fax: (404) 305-2046

Agency Code: **060401J**

ORI:

5021 old Martin

Incident No. **2007458**

Ticket No: **800245**

Arrest No.

DL#: (

800245
PHILLIP NAVES

SSN: -

Sex: **MALE**

DOB: (

Race: **BLACK**

Age: **35**

ATLANTA, GA 30311

VEHICLE INFORMATION

TAG #: _____
 DESCRIPTION: _____

STATE: _____

YEAR: _____

VIOLATION INFORMATION

Initial Charge: **ALCOH BEV PROHIBITED HRS SALES BY DRINK**

Statute: _____

Convicted Charge: **ALCOH BEV PROHIBITED HRS SALES BY DRINK**

Statute: _____

BAC %: **.0**

Speed: _____

Zone: _____

Date of Violation: **07/11/2020**

Officer: **SHANIECE DURDEN**

Badge No: **2628**

Complainant: _____

Date of Judgment: **01/13/2021**

Judgment of Court: **Guilty**

Judge: **MONICA EWING**

Represented by (if any): _____

Appointed (if any): _____

Remarks: _____

PROBATION:

END DATE:

WITH:

DEFENDANT WAS FINED:

BAIL FORFEITED:

FINE AMOUNT \$: 98.40

FINE PAID:

PLUS ASSESSMENTS OF \$: 46.60

APPEALED:

FOR A TOTAL OF \$: 145.00

SENTENCED TO:

- PAYMENTS \$: 145.00

Years in Jail,

TOTAL \$: 0.00

Months in Jail,

Days in Jail.



I certify that this is a true and correct copy of my court record.

SIGNED _____

04/30/2021

DOCKET: 800245

Court Clerk / Deputy Court Clerk

COLLEGE PARK MUNICIPAL COURT
COLLEGE PARK MUNICIPAL COURT
3717 COLLEGE ST
COLLEGE PARK, GA 30337

ABSTRACT OF COURT RECORD
STATE OF GEORGIA
FULTON COUNTY
CITY OF COLLEGE PARK

Phone: (404) 761-3131
Fax: (404) 305-2046

Agency Code: **060401J**

ORI:

Incident No. **2011435**

Ticket No: **70761**

Arrest No.

DL#:

70761

ANTHONY DEMETRIUS FLOWERS

SSN: -

Sex: **MALE**

DOB:

COLLEGE PARK, GA 30349

Race: **BLACK**

Age: **52**

VEHICLE INFORMATION	TAG #: DESCRIPTION:	STATE:	YEAR:
---------------------	------------------------	--------	-------

VIOLATION INFORMATION Initial Charge: **DISORDERLY CONDUCT (512)**
 Statute:
 Convicted Charge: **DISORDERLY CONDUCT (512)**
 Statute:
 BAC %: **.0** Speed: Zone:
 Date of Violation: **11/15/2020**
 Officer: **SHANIECE DURDEN** Badge No: **2628**
 Complainant:
 Date of Judgment: **03/17/2021** Judgment of Court: **Guilty**
 Judge: **MONICA EWING**
 Represented by (if any):
 Appointed (if any):
 Remarks:

PROBATION:	END DATE:	WITH:
DEFENDANT WAS FINED:		BAIL FORFEITED: <input type="checkbox"/>
FINE AMOUNT \$: 150.40		FINE PAID: <input type="checkbox"/>
PLUS ASSESSMENTS OF \$: 59.60		APPEALED: <input type="checkbox"/>
FOR A TOTAL OF \$: 210.00		SENTENCED TO:
- PAYMENTS \$: 210.00		Years in Jail,
TOTAL \$: 0.00		Months in Jail,
		Days in Jail.



I certify that this is a true and correct copy of my court record.

SIGNED _____ 04/30/2021

DOCKET: 70761

Court Clerk / Deputy Court Clerk

COLLEGE PARK MUNICIPAL COURT
 COLLEGE PARK MUNICIPAL COURT
 3717 COLLEGE ST
 COLLEGE PARK, GA 30337

Phone: (404) 761-3131
 Fax: (404) 305-2046

ABSTRACT OF COURT RECORD
STATE OF GEORGIA
FULTON COUNTY
CITY OF COLLEGE PARK

Agency Code: **060401J**

ORI:

Incident No. **2011435**

Ticket No: **70762A**

Arrest No.

DL#:

SSN: -

Sex: **MALE**

DOB:

Race: **BLACK**

Age: **52**

70762A

ANTHONY DEMETRIUS FLOWERS

COLLEGE PARK, GA 30349

VEHICLE INFORMATION

TAG #:

STATE:

YEAR:

DESCRIPTION:

VIOLATION INFORMATION

Initial Charge: **MAINTAINING A DIVE**

Statute:

Convicted Charge: **MAINTAINING A DIVE**

Statute:

BAC %: **.0**

Speed:

Zone:

Date of Violation: **11/15/2020**

Officer: **SHANIECE DURDEN**

Badge No: **2628**

Complainant:

Date of Judgment: **03/17/2021**

Judgment of Court: **Guilty**

Judge: **MONICA EWING**

Represented by (if any):

Appointed (if any):

Remarks:

PROBATION:

END DATE:

WITH:

DEFENDANT WAS FINED:

BAIL FORFEITED:

FINE AMOUNT \$: **515.65**

FINE PAID:

PLUS ASSESSMENTS OF \$: **149.35**

APPEALED:

FOR A TOTAL OF \$: **665.00**

SENTENCED TO:

- PAYMENTS \$: **665.00**

Years in Jail,

TOTAL \$: **0.00**

Months in Jail,

Days in Jail.



I certify that this is a true and correct copy of my court record.

SIGNED _____

04/30/2021

DOCKET: 70762A

Court Clerk / Deputy Court Clerk

COLLEGE PARK MUNICIPAL COURT
 COLLEGE PARK MUNICIPAL COURT
 3717 COLLEGE ST
 COLLEGE PARK, GA 30337

Phone: (404) 761-3131
 Fax: (404) 305-2046

ABSTRACT OF COURT RECORD
STATE OF GEORGIA
FULTON COUNTY
CITY OF COLLEGE PARK

Agency Code: **060401J**

ORI:

Incident No. **2011435**

Ticket No: **70770A**

Arrest No.

DL#:

SSN: -

DOB: i

Age: **52**

70770A

ANTHONY DEMETRIUS FLOWERS

Sex: **MALE**

Race: **BLACK**

COLLEGE PARK, GA 30349

VEHICLE INFORMATION

TAG #: _____
 DESCRIPTION: _____

STATE: _____

YEAR: _____

VIOLATION INFORMATION

Initial Charge: **MAINTAINING A DIVE**

Statute:

Convicted Charge: **MAINTAINING A DIVE**

Statute:

BAC %: **.0**

Speed:

Zone:

Date of Violation: **11/15/2020**

Officer: **SHANIECE DURDEN**

Badge No: **2628**

Complainant:

Date of Judgment: **03/17/2021**

Judgment of Court: **Guilty**

Judge: **MONICA EWING**

Represented by (if any):

Appointed (if any):

Remarks:

PROBATION:

END DATE:

WITH:

DEFENDANT WAS FINED:

BAIL FORFEITED:

FINE AMOUNT \$: **515.65**

FINE PAID:

PLUS ASSESSMENTS OF \$: **149.35**

APPEALED:

FOR A TOTAL OF \$: **665.00**

SENTENCED TO:

- PAYMENTS \$: **665.00**

Years in Jail,

TOTAL \$: **0.00**

Months in Jail,

Days in Jail.



I certify that this is a true and correct copy of my court record.

SIGNED _____

04/30/2021

DOCKET: 70770A

Court Clerk / Deputy Court Clerk

COLLEGE PARK MUNICIPAL COURT
COLLEGE PARK MUNICIPAL COURT
3717 COLLEGE ST
COLLEGE PARK, GA 30337

Phone: (404) 761-3131
Fax: (404) 305-2046

ABSTRACT OF COURT RECORD

STATE OF GEORGIA

FULTON COUNTY

CITY OF COLLEGE PARK

Agency Code: **060401J**

ORI:

Incident No. **2011435**

Ticket No: **72735**

Arrest No.

DL#:

SSN: -

DOB: -

Sex: **MALE**

Race: **BLACK**

Age: **54**

72735

ANTHONY DEMETRIUS FLOWERS

COLLEGE PARK, GA 30349

**VEHICLE
INFORMATION**

TAG #:

STATE:

YEAR:

DESCRIPTION:

**VIOLATION
INFORMATION**

Initial Charge: **MAINTAINING A DIVE**

Statute:

Convicted Charge: **MAINTAINING A DIVE**

Statute:

BAC %: **.0**

Speed:

Zone:

Date of Violation: **11/15/2020**

Officer: **SHANIECE DURDEN**

Badge No: **2628**

Complainant:

Date of Judgment: **03/17/2021**

Judgment of Court: **Guilty**

Judge: **MONICA EWING**

Represented by (if any):

Appointed (if any):

Remarks:

NO FINE

PROBATION:

END DATE:

WITH:

DEFENDANT WAS FINED:

BAIL FORFEITED:

FINE AMOUNT \$: **0.00**

FINE PAID:

PLUS ASSESSMENTS OF \$: **0.00**

APPEALED:

FOR A TOTAL OF \$: **0.00**

SENTENCED TO:

- PAYMENTS \$: **0.00**

Years in Jail,

TOTAL \$: **0.00**

Months in Jail,

Days in Jail.



I certify that this is a true and correct copy of my court record.

SIGNED _____

04/30/2021

DOCKET: 72735

Court Clerk / Deputy Court Clerk

COLLEGE PARK MUNICIPAL COURT
 COLLEGE PARK MUNICIPAL COURT
 3717 COLLEGE ST
 COLLEGE PARK, GA 30337

Phone: (404) 761-3131
 Fax: (404) 305-2046

ABSTRACT OF COURT RECORD
STATE OF GEORGIA
FULTON COUNTY
CITY OF COLLEGE PARK

Agency Code: **060401J**

ORI:

Incident No. **2011435**

Ticket No: **73187**

Arrest No.

DL#:

SSN: -

DOB:

Age: **52**

73187

ANTHONY DEMETRIUS FLOWERS

Sex: **MALE**

Race: **BLACK**

COLLEGE PARK, GA 30349

VEHICLE INFORMATION

TAG #: _____
 DESCRIPTION: _____

STATE: _____

YEAR: _____

VIOLATION INFORMATION

Initial Charge: **MAINTAINING A DIVE**

Statute: _____

Convicted Charge: **MAINTAINING A DIVE**

Statute: _____

BAC %: **.0**

Speed: _____

Zone: _____

Date of Violation: **11/15/2020**

Officer: **SHANIECE DURDEN**

Badge No: **2628**

Complainant: _____

Date of Judgment: **03/17/2021**

Judgment of Court: **Guilty**

Judge: **MONICA EWING**

Represented by (if any): _____

Appointed (if any): _____

Remarks:

TOTAL 3710.00 FOR 9 CITATIONS

PROBATION:

END DATE:

WITH:

DEFENDANT WAS FINED:

BAIL FORFEITED:

FINE AMOUNT \$: 515.65

FINE PAID:

PLUS ASSESSMENTS OF \$: 149.35

APPEALED:

FOR A TOTAL OF \$: 665.00

SENTENCED TO:

- PAYMENTS \$: 665.00

Years in Jail,
 Months in Jail,
 Days in Jail.

TOTAL \$: 0.00



I certify that this is a true and correct copy of my court record.

SIGNED _____

04/30/2021

DOCKET: 73187

Court Clerk / Deputy Court Clerk

COLLEGE PARK MUNICIPAL COURT
COLLEGE PARK MUNICIPAL COURT
3717 COLLEGE ST
COLLEGE PARK, GA 30337

ABSTRACT OF COURT RECORD
STATE OF GEORGIA
FULTON COUNTY
CITY OF COLLEGE PARK

Phone: (404) 761-3131
Fax: (404) 305-2046

Agency Code: **060401J**

ORI:

5021 Old Nathan/

Incident No. **2007458**

Ticket No: **800243**

Arrest No.

DL#:

800243
PHILLIP NAVES

SSN: -

ATLANTA, GA 30311

Sex: **MALE**
Race: **BLACK**

DOB:
Age: **35**

VEHICLE INFORMATION	TAG #: DESCRIPTION:	STATE:	YEAR:
---------------------	------------------------	--------	-------

VIOLATION INFORMATION Initial Charge: **MAINTAINING A DIVE**
Statute:
Convicted Charge: **MAINTAINING A DIVE**
Statute:
BAC %: **.0** Speed: Zone:
Date of Violation: **07/11/2020**
Officer: **SHANIECE DURDEN** Badge No: **2628**
Complainant:
Date of Judgment: **01/13/2021** Judgment of Court: **Guilty**
Judge: **MONICA EWING**
Represented by (if any):
Appointed (if any):
Remarks:

PROBATION:	END DATE:	WITH:
DEFENDANT WAS FINED:		BAIL FORFEITED: <input type="checkbox"/>
FINE AMOUNT \$: 515.65		FINE PAID: <input type="checkbox"/>
PLUS ASSESSMENTS OF \$: 149.35		APPEALED: <input type="checkbox"/>
FOR A TOTAL OF \$: 665.00	SENTENCED TO:	
- PAYMENTS \$: 665.00	Years in Jail,	
TOTAL \$: 0.00	Months in Jail,	
	Days in Jail.	



I certify that this is a true and correct copy of my court record.

SIGNED _____ 04/30/2021

DOCKET: 800243

Court Clerk / Deputy Court Clerk

COLLEGE PARK MUNICIPAL COURT
 COLLEGE PARK MUNICIPAL COURT
 3717 COLLEGE ST
 COLLEGE PARK, GA 30337

ABSTRACT OF COURT RECORD
STATE OF GEORGIA
FULTON COUNTY
CITY OF COLLEGE PARK

Phone: (404) 761-3131
 Fax: (404) 305-2046

Agency Code: **060401J**

ORI:

Incident No. **2011435**

Ticket No: **70769A**

Arrest No.

DL#:

70769A
ANTHONY DFMFTRIIIS FLOWERS

SSN: -

Sex: **MALE**

DOB:

COLLEGE PARK, GA 30349

Race: **BLACK**

Age: **52**

VEHICLE INFORMATION

TAG #: _____
 DESCRIPTION: _____

STATE: _____

YEAR: _____

VIOLATION INFORMATION

Initial Charge: **DISORDERLY CONDUCT (512)**

Statute:

Convicted Charge: **DISORDERLY CONDUCT (512)**

Statute:

BAC %: **.0**

Speed:

Zone:

Date of Violation: **11/15/2020**

Officer: **SHANIECE DURDEN**

Badge No: **2628**

Complainant:

Date of Judgment: **03/17/2021**

Judgment of Court: **Guilty**

Judge: **MONICA EWING**

Represented by (if any):

Appointed (if any):

Remarks:

PROBATION:

END DATE:

WITH:

DEFENDANT WAS FINED:

BAIL FORFEITED:

FINE AMOUNT \$: **150.40**

FINE PAID:

PLUS ASSESSMENTS OF \$: **59.60**

APPEALED:

FOR A TOTAL OF \$: **210.00**

SENTENCED TO:

- PAYMENTS \$: **210.00**

Years in Jail,

TOTAL \$: **0.00**

Months in Jail,

Days in Jail.



I certify that this is a true and correct copy of my court record.

SIGNED _____

04/30/2021

DOCKET: 70769A

Court Clerk / Deputy Court Clerk

COLLEGE PARK MUNICIPAL COURT
COLLEGE PARK MUNICIPAL COURT
3717 COLLEGE ST
COLLEGE PARK, GA 30337

ABSTRACT OF COURT RECORD
STATE OF GEORGIA
FULTON COUNTY
CITY OF COLLEGE PARK

Phone: (404) 761-3131
Fax: (404) 305-2046

Agency Code: **060401J**

ORI:

Incident No. **2011435**

Ticket No: **73188**

Arrest No.

DL#:

73188

ANTHONY DEMETRIUS FLOWERS

SSN: -

Sex: **MALE**

DOB: |

COLLEGE PARK, GA 30349

Race: **BLACK**

Age: **52**

VEHICLE INFORMATION

TAG #:

STATE:

YEAR:

DESCRIPTION:

VIOLATION INFORMATION

Initial Charge: **DISORDERLY CONDUCT (512)**

Statute:

Convicted Charge: **DISORDERLY CONDUCT (512)**

Statute:

BAC %: **.0**

Speed:

Zone:

Date of Violation: **11/15/2020**

Officer: **SHANIECE DURDEN**

Badge No: **2628**

Complainant:

Date of Judgment: **03/17/2021**

Judgment of Court: **Guilty**

Judge: **MONICA EWING**

Represented by (if any):

Appointed (if any):

Remarks:
NO FINE

PROBATION:

END DATE:

WITH:

DEFENDANT WAS FINED:

BAIL FORFEITED:

FINE AMOUNT \$: 150.40

FINE PAID:

PLUS ASSESSMENTS OF \$: 59.60

APPEALED:

FOR A TOTAL OF \$: 210.00

SENTENCED TO:

- PAYMENTS \$: 210.00

**Years in Jail,
Months in Jail,
Days in Jail.**

TOTAL \$: 0.00



I certify that this is a true and correct copy of my court record.

SIGNED

04/30/2021

DOCKET: 73188

Court Clerk / Deputy Court Clerk

COLLEGE PARK MUNICIPAL COURT
 COLLEGE PARK MUNICIPAL COURT
 3717 COLLEGE ST
 COLLEGE PARK, GA 30337

Phone: (404) 761-3131
 Fax: (404) 305-2046

ABSTRACT OF COURT RECORD
STATE OF GEORGIA
FULTON COUNTY
CITY OF COLLEGE PARK

Agency Code: **060401J**

ORI:

Incident No. **2011435**

Ticket No: **73198**

Arrest No.

DL#:

SSN: -

DOB:

Age: **52**

Sex: **MALE**

Race: **BLACK**

73198

COLLEGE PARK, GA 30349

VEHICLE INFORMATION

TAG #: _____
 DESCRIPTION: _____

STATE: _____

YEAR: _____

VIOLATION INFORMATION

Initial Charge: **DISORDERLY CONDUCT (512)**

Statute:

Convicted Charge: **DISORDERLY CONDUCT (512)**

Statute:

BAC %: **.0**

Speed:

Zone:

Date of Violation: **11/15/2020**

Officer: **SHANIECE DURDEN**

Badge No: **2628**

Complainant:

Date of Judgment: **03/17/2021**

Judgment of Court: **Guilty**

Judge: **MONICA EWING**

Represented by (if any):

Appointed (if any):

Remarks:

PROBATION:

END DATE:

WITH:

DEFENDANT WAS FINED:

FINE AMOUNT \$: **150.40**

PLUS ASSESSMENTS OF \$: **59.60**

FOR A TOTAL OF \$: **210.00**

- PAYMENTS \$: **210.00**

TOTAL \$: **0.00**

BAIL FORFEITED:

FINE PAID:

APPEALED:

SENTENCED TO:

Years in Jail,
 Months in Jail,
 Days in Jail.



I certify that this is a true and correct copy of my court record.

SIGNED _____

04/30/2021

DOCKET: 73198

Court Clerk / Deputy Court Clerk

COLLEGE PARK MUNICIPAL COURT
COLLEGE PARK MUNICIPAL COURT
3717 COLLEGE ST
COLLEGE PARK, GA 30337

ABSTRACT OF COURT RECORD
STATE OF GEORGIA
FULTON COUNTY
CITY OF COLLEGE PARK

Phone: (404) 761-3131
Fax: (404) 305-2046

Agency Code: **060401J**

ORI:

5021 old nation

Incident No. **2007458**

Ticket No: **800244**

Arrest No.

DL#:

800244

PHILLIP A NAVES

SSN: -

Sex: **MALE**

DOB:

ATLANTA, GA 30311

Race:

Age: **35**

**VEHICLE
INFORMATION**

TAG #:
DESCRIPTION:

STATE:

YEAR:

**VIOLATION
INFORMATION**

Initial Charge: **DISORDERLY CONDUCT (512)**

Statute:

Convicted Charge: **DISORDERLY CONDUCT (512)**

Statute:

BAC %:

Speed:

Zone:

Date of Violation: **07/13/2020**

Officer: **SHANIECE DURDEN**

Badge No: **2628**

Complainant:

Date of Judgment: **01/13/2021**

Judgment of Court: **Guilty**

Judge: **MONICA EWING**

Represented by (if any):

Appointed (if any):

Remarks:

PROBATION:

END DATE:

WITH:

DEFENDANT WAS FINED:

BAIL FORFEITED:

FINE AMOUNT \$: 150.40

FINE PAID:

PLUS ASSESSMENTS OF \$: 59.60

APPEALED:

FOR A TOTAL OF \$: 210.00

SENTENCED TO:

- PAYMENTS \$: 210.00

Years in Jail,
Months in Jail,
Days in Jail.

TOTAL \$: 0.00



I certify that this is a true and correct copy of my court record.

SIGNED

04/30/2021

DOCKET: 800244

Court Clerk / Deputy Court Clerk



CITY OF COLLEGE PARK

P.O. BOX 87137 • COLLEGE PARK, GA. 30337 • 404/767-1537

August 17, 2021

Ms. Betty Whitaker
WRAITH
5021 Old National Highway
College Park, GA 30337

Delivered Via:
Certified Mail
Hand Delivered
Email

RE: Alcoholic Beverage Violation

Dear Ms. Whitaker:

Per Section 3-46 of the City of College Park's Code of Ordinances - Suspension or revocation of license:

"A license may be suspended or revoked by the city for any violation of this chapter; for any violation of state laws and regulations relating to alcoholic beverages; for any material misrepresentation or omission in the application for the license; or if the licensee or the licensed business ceases to meet the eligibility requirements for licensure".

The City of College Park Mayor and Council met in regular session on Monday, August 16, 2021, and agreed with the recommendation that your business located at 5021 Old National Highway College Park, GA 30337 should **cease to sell alcoholic beverages beginning on August 17, 2021 to November 15, 2021**. In addition to the 90-day suspension you are also required to pay a **Civil Penalty of \$5000.00**.

This action is a result of guilty dispositions regarding after hour purchases of alcoholic beverages, maintaining a dive, and/or disorderly conduct that took place on June 11, 2020, June 13, 2020 and November 15, 2020.

If you have questions, please call us at (404) 669-3754.

Sincerely,

Shavala Moore
City Clerk

cc: Mercedes Miller, Interim City Manager
Tom Kuniacki, Interim Police Chief
Nathan Ward, Major

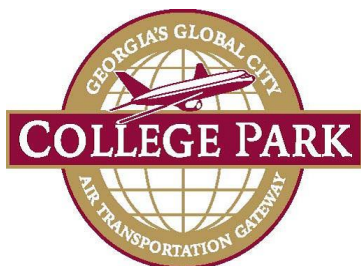

CITY OF COLLEGE PARK

P.O. BOX 87137 · COLLEGE PARK, GA 30337 · 404.767.1537

REG SESSION AGENDA REQUEST

DOC ID: 9085

DATE: September 1, 2021

TO: The Honorable Mayor and Members of City Council

FROM: Mercedes Miller, Interim City Manager

RE: Homestead Tax Exemption for Seniors

The tax exemption approved for fully homestead exempt residents by Fulton County Tax has to go before the General Assembly as a local legislation item in the upcoming 2022 session.

This item must be presented by the local delegation and approved by the General Assembly. A resolution and draft legislation is attached. January is the absolute soonest the legislation can act on this legislation to give the citizens this needed tax relief.

Thank you.

ATTACHMENTS:

- CP- Full Value Homestead Exemption Resolution (DOCX)
- Draft Legislation- Full Value Homestead(DOCX)

Review:

- Mercedes Miller Completed 08/31/2021 4:55 PM
- Rosyline Robinson Completed 08/31/2021 4:57 PM
- City Attorney's Office Completed 08/31/2021 8:54 PM
- Mercedes Miller Completed 09/01/2021 1:42 PM
- Mayor & City Council Pending 09/07/2021 7:30 PM

STATE OF GEORGIA

CITY OF COLLEGE PARK

RESOLUTION NO. 2021- 19

1 A RESOLUTION OF THE MAYOR AND COUNCIL OF THE CITY OF COLLEGE PARK,
 2 GEORGIA, RESPECTFULLY REQUESTING THAT THE FULTON COUNTY AND
 3 CLAYTON COUNTY LEGISLATIVE DELEGATIONS INTRODUCE LEGISLATION
 4 DURING THE 2022 SESSION OF THE GEORGIA GENERAL ASSEMBLY TO PROVIDE
 5 FOR A LOCAL REFERENDUM TO ADOPT A FULL VALUE HOMESTEAD EXEMPTION
 6 FOR CERTAIN CITY RESIDENTS WHO ARE 70 YEARS OF AGE OR OVER OR DISABLED
 7 AND MEET CERTAIN INCOME REQUIREMENTS; TO PROVIDE AN EFFECTIVE DATE;
 8 AND FOR OTHER PURPOSES.

9 **WHEREAS**, the City of College Park (“City”) is a municipal corporation duly organized
 10 and existing under the laws of the State of Georgia; and

11 **WHEREAS**, the duly elected governing authority of the City is comprised of the Mayor
 12 and Council thereof; and

13 **WHEREAS**, housing is a basic need that should be accessible to all, and that
 14 homeownership is a way to build wealth, a feeling of safety, and stability for individuals and
 15 families; and

16 **WHEREAS**, the Mayor and Council, in the exercise of their sound judgment and
 17 discretion, after giving thorough consideration to all the implications involved, and keeping in
 18 mind the public interest and welfare of the citizens of the City, have determined that providing a
 19 City-level full value homestead exemption to City residents similar to Fulton County’s full value
 20 homestead exemptions for certain seniors and disabled persons would benefit the citizens of the

21 City; and

22 **WHEREAS**, the Mayor and Council find that it is in the best interest of the citizens of the
23 City to request the assistance of the Fulton County and Clayton County Legislative Delegations in
24 introducing the necessary legislation for implementing a homestead exemption for such City
25 residents,

26 **THEREFORE, BE IT AND IT IS HEREBY RESOLVED** by the Mayor and Council
27 of the City of College Park, Georgia, and by the authority thereof that:

28 **Section 1.** The Mayor and Council respectfully request that the Fulton County and Clayton
29 County Legislative Delegations introduce legislation for consideration by the General Assembly
30 in the 2022 session providing for an exemption for the full value of the homestead from all City
31 of College Park ad valorem taxes levied for municipal government purposes, including ad valorem
32 taxes levied to pay interest on and retire bonded indebtedness of the municipal government, for
33 each resident of College Park who is 70 years of age or over or disabled if the resident's gross
34 income, together with the gross income of the spouse residing at the same homestead, does not
35 exceed the amount which may be received by a person and a person's spouse under the federal
36 Social Security Act.

37 **Section 2.** The preamble of this Resolution shall be considered to be and is hereby
38 incorporated by reference as if fully set out herein.

39 **Section 3.** (a) It is hereby declared to be the intention of the Mayor and Council that all
40 sections, paragraphs, sentences, clauses, and phrases of this Resolution are or were, upon their
41 enactment, believed by the Mayor and Council to be fully valid, enforceable, and constitutional.

42 (b) It is hereby declared to be the intention of the Mayor and Council that, to the greatest
43 extent allowed by law, each and every section, paragraph, sentence, clause, or phrase of this

44 Resolution is severable from every other section, paragraph, sentence, clause, or phrase of this
45 Resolution. It is hereby further declared to be the intention of the Mayor and Council that, to the
46 greatest extent allowed by law, no section, paragraph, sentence, clause, or phrase of this Resolution
47 is mutually dependent upon any other section, paragraph, sentence, clause, or phrase of this
48 Resolution.

49 (c) In the event that any phrase, clause, sentence, paragraph, or section of this Resolution
50 shall, for any reason whatsoever, be declared invalid, unconstitutional, or otherwise unenforceable
51 by the valid judgment or decree of any court of competent jurisdiction, it is the express intent of
52 the Mayor and Council that such invalidity, unconstitutionality, or unenforceability shall, to the
53 greatest extent allowed by law, not render invalid, unconstitutional, or otherwise unenforceable
54 any of the remaining phrases, clauses, sentences, paragraphs, or sections of the Resolution and
55 that, to the greatest extent allowed by law, all remaining phrases, clauses, sentences, paragraphs,
56 and sections of the Resolution shall remain valid, constitutional, enforceable, and of full force and
57 effect.

58 **Section 4.** All resolutions and parts of resolutions in conflict herewith are hereby expressly
59 repealed.

60 **Section 5.** The effective date of this Resolution shall be the date of adoption unless
61 otherwise specified herein.

RESOLVED this _____ day of _____, 2021.

CITY OF COLLEGE PARK, GEORGIA

Bianca Motley Broom, Mayor

ATTEST:

Shavala Moore, City Clerk

APPROVED AS TO FORM:

City Attorney

A BILL TO BE ENTITLED

AN ACT

1 To provide an exemption for the full value of the homestead from all City of College
 2 Park ad valorem taxes levied for municipal government purposes, including ad
 3 valorem taxes levied to pay interest on and retire bonded indebtedness of the
 4 municipal government, for each resident of College Park who is 70 years of age or
 5 over or disabled if the resident's gross income, together with the gross income of the
 6 spouse residing at the same homestead, does not exceed the amount which may be
 7 received by a person and a person's spouse under the federal Social Security Act; to
 8 provide for other matters relative to the foregoing; to repeal specific laws; to provide
 9 for a referendum; to repeal conflicting laws; and for other purposes.

10 BE IT ENACTED BY THE GENERAL ASSEMBLY OF GEORGIA:

11 style="text-align:center">**SECTION 1.**

12 (a) As used in this Act, the term:

13 (1) "Ad valorem taxes for municipal purposes" means all ad valorem taxes for
 14 municipal purposes levied by, for, or on behalf of the City of College Park,
 15 including, but not limited to, any ad valorem taxes to pay interest on and to
 16 retire municipal bonded indebtedness.

17 (2) "Homestead" means homestead as defined and qualified in Code Section
 18 48-5-40 of the O.C.G.A., as amended.

19 (3) "Income" means adjusted gross income determined pursuant to the Internal
 20 Revenue Code of 1986, as amended, for federal income tax purposes, except

21 that for the purposes of this section the term shall include only that portion of
22 income or benefits received as retirement, survivor, or disability benefits
23 under the federal Social Security Act or under any other public or private
24 retirement, disability, or pension system which exceeds the maximum amount
25 which may be received by an individual and an individual's spouse under the
26 federal Social Security Act.

27 (4) "Senior citizen" means a person who is 70 years of age or over on or before
28 January 1 of the year in which application for the exemption under subsection
29 (b) of this section is made.

30 (b) Each resident of the City of College Park who is a senior citizen or who is
31 disabled is granted an exemption on that person's homestead from City of College
32 Park ad valorem taxes for municipal purposes for the full value of that homestead.
33 The exemption granted by this subsection shall only be granted if that person's
34 income, together with the income of the spouse who also occupies and resides at
35 such homestead, does not exceed the maximum amount which may be received by
36 an individual and an individual's spouse under the federal Social Security Act for the
37 immediately preceding year.

38 (c)(1) In order to qualify for the exemption provided for in subsection (b) of
39 this section as being disabled, the person claiming such exemption shall be
40 required to obtain a certificate from not more than three physicians licensed
41 to practice medicine under Chapter 34 of Title 43 of the O.C.G.A., as
42 amended, certifying that in the opinion of such physician or physicians such
43 person is mentally or physically incapacitated to the extent that such person is
44 unable to be gainfully employed and that such incapacity is likely to be
45 permanent. Such certificate or certificates shall constitute part of and be

46 submitted with the application provided for in paragraph (2) of this
47 subsection.

48 (2) A person shall not receive the homestead exemption granted by subsection
49 (b) of this section unless the person or person's agent files an application with
50 the governing authority of the City of College Park, or the designee thereof,
51 giving the person's age, income, and such additional information relative to
52 receiving such exemption as will enable the governing authority of the City
53 of College Park, or the designee thereof, to make a determination regarding
54 the initial and continuing eligibility of such person for such exemption. The
55 governing authority of the City of College Park, or the designee thereof, shall
56 provide application forms for this purpose.

57 (d) The exemption shall be claimed and returned as provided in Code Section 48-5-
58 50.1 of the O.C.G.A., as amended. The exemption shall be automatically renewed
59 from year to year so long as the owner occupies the residence as a homestead. After
60 a person has filed the proper application, as provided in subsection (c) of this section,
61 it shall not be necessary to make application thereafter for any year and the
62 exemption shall continue to be allowed to such person. It shall be the duty of any
63 person granted the homestead exemption under subsection (b) of this section to
64 notify the governing authority of the City of College Park, or the designee thereof,
65 in the event that person for any reason becomes ineligible for that exemption.

66 (e) The exemption granted by subsection (b) of this section shall not apply to or
67 affect state ad valorem taxes, county ad valorem taxes for county purposes, or county
68 or independent school district ad valorem taxes for educational purposes. The
69 homestead exemption granted by subsection (b) of this section shall be in addition
70 to and not in lieu of any other homestead exemption applicable to municipal ad
71 valorem taxes for municipal purposes.

72 (f) The exemption granted by subsection (b) of this section shall apply to all taxable
73 years beginning on or after January 1, 2023.

74 **SECTION 2.**

75 The municipal election superintendent of the City of College Park shall call and
76 conduct an election as provided in this section for the purpose of submitting this Act
77 to the electors of the City of College Park for approval or rejection. The municipal
78 election superintendent shall conduct that election on the Tuesday after the first
79 Monday in November, 2022, and shall issue the call and conduct that election as
80 provided by general law. The municipal election superintendent shall cause the date
81 and purpose of the election to be published once a week for two weeks immediately
82 preceding the date thereof in the official organs of Fulton County and Clayton
83 County. The ballot shall have written or printed thereon the words:

84 “() YES Shall the Act be approved which provides an exemption for the full
85 () NO value of the homestead from all City of College Park ad valorem taxes
86 levied for municipal government purposes, including ad valorem taxes
87 levied to pay interest on and retire bonded indebtedness of the
88 municipal government, for each resident of College Park who is 70
89 years of age or over or disabled if the resident's gross income, together
90 with the gross income of the spouse residing at the same homestead,
91 does not exceed the amount which may be received by a person and a
92 person's spouse under the federal Social Security Act?”

93 All persons desiring to vote for approval of the Act shall vote "Yes," and all persons
94 desiring to vote for rejection of the Act shall vote "No." If more than one-half of
95 the votes cast on such question are for approval of the Act, Section 1 of this Act
96 shall become of full force and effect on January 1, 2023. If the Act is not so

97 approved or if the election is not conducted as provided in this section, Section 1
98 of this Act shall not become effective and this Act shall be automatically repealed
99 on the first day of January immediately following that election date. The expense
100 of such election shall be borne by the City of College Park. It shall be the municipal
101 election superintendent's duty to certify the result thereof to the Secretary of State.

102 **SECTION 3.**

103 Except as otherwise provided in Section 2 of this Act, this Act shall become effective
104 upon its approval by the Governor or upon its becoming law without such approval.

105 **SECTION 4.**

106 All laws and parts of laws in conflict with this Act are repealed.



CITY OF COLLEGE PARK

P.O. BOX 87137 · COLLEGE PARK, GA 30337 · 404.767.1537

REG SESSION AGENDA REQUEST

DOC ID: 9072

DATE: September 1, 2021

TO: The Honorable Mayor and Members of City Council

THROUGH: Mercedes Miller, Interim City Manager

FROM: Artie Jones, Director of Economic Development

RE: CPMSA Public Art Project

PURPOSE:

Mayor and Council consideration in authorizing the Main Street Manager, Renee Coakley, and CPMSA to install an art structure on Main Street (and in the future, other areas within the Main Street Program Area).

REASON: In an effort to enhance Placemaking within the College Park Main Street Program Area, CPMSA would like to install an art structure in areas of Main Street beginning with this initial piece (please see attachment for dimensions, location, etc.).

RECOMMENDATION: It is recommended for approval for enhancement of the program area.

BACKGROUND: See attached documentation.

YEARS OF SERVICE: N/A

COST TO CITY: CPMSA will pay cost of one year lease for structure and insurance to cover the structure. A small concrete base will need to be constructed and will be facilitated by Public Works.

BUDGETED ITEM: N/A

REVENUE TO CITY: N/A

CITY COUNCIL HEARING DATE: September 7, 2021

CONSIDERATION BY OTHER GOVERNMENT ENTITIES: N/A

AFFECTED AGENCIES: N/A

RELATIONSHIP TO EXISTING ORDINANCE OR RESOLUTION: N/A

REQUIRED CHANGES TO WORK PROGRAMS:

STAFF: Renee Coakley, Main Street Manager
Artie Jones, III Economic Development Director

ATTACHMENTS:

- Main Street Public Art Project for council approval (PDF)

Review:

- Artie Jones Completed 08/27/2021 1:57 PM
- Rosyline Robinson Completed 08/27/2021 4:37 PM
- Melissa Echevarria Completed 08/31/2021 9:22 AM
- City Attorney's Office Completed 09/01/2021 12:28 PM
- Artie Jones Completed 08/27/2021 1:59 PM
- Mercedes Miller Completed 09/01/2021 1:42 PM
- Mayor & City Council Pending 09/07/2021 7:30 PM

Main Street Public Art Project

Gregory Johnson (artist)

Nucleus- 70x30x25"- sculpture depicting energy and growth, needs a 30x36" pad or level concrete surface. (PW Director agreed that this can be created in house)

- CPMSA will pay lease fee for one year \$1,000. Piece can be purchased after the 1 year for \$10,875,00 less \$,1,000 initial lease payment.
- Artist will install. City only needs to supply electricity within 100' for install, or provide a generator. It is two 5/8" holes in the concrete with anchors, then bolted down. Delivery and pick up is included.
- Location (bare area at John Wesley MARTA entrance)

