



# Mayor & City Council

## Workshop Session

~ Agenda ~

City of College Park  
3667 Main Street  
College Park, GA 30337

<http://www.collegeparkga.com>  
404-669-3756 (Main)

Experience College Park  
Georgia's Global City

---

**Monday, December 6, 2021**

**6:00 PM**

**Council Chambers**

---

1. Distribution Automation for Electric Power Restoration. See attached presentation and memorandum dated November 29, 2021, from Power Director, Hugh Richardson.
2. Review of a Licensing Food Truck Ordinance. See memorandum dated November 29, 2021, from City Planner Nikki Washington. Also, see attached supporting documentation.



# CITY OF COLLEGE PARK

P.O. BOX 87137 · COLLEGE PARK, GA 30337 · 404.767.1537

## WORKSHOP AGENDA ITEM

DOC ID: 9262

**DATE:** November 29, 2021

**TO:** The Honorable Mayor and Members of City Council

**THROUGH:** Mercedes Miller, Interim City Manager

**FROM:** Hugh Richardson, Power Director

**RE:** Distribution Automation for Electric Power Restoration

**PURPOSE:** To review how Distribution Automation (DA) works and how it can benefit power restoration during storms.

**REASON:** In order to enhance power reliability and faster restoration of power, distribution automation is an essential added technology.

**RECOMMENDATION:** Presentation review

**BACKGROUND:** The Power Department has 152 miles of power lines throughout the City and served from 7 different substations. The circuits have strategic locations for gang operated switches (GOS) to pick up load from other circuits, however, the GOS are manually operated.

**COST TO CITY:** To be presented in regular session

**BUDGETED ITEM:** Yes

**REVENUE TO CITY:** N/A

**CITY COUNCIL HEARING DATE:** Dec. 6, 2021

**CONSIDERATION BY OTHER GOVERNMENT ENTITIES:** N/A

**AFFECTED AGENCIES:** N/A

**RELATIONSHIP TO EXISTING ORDINANCE OR RESOLUTION:** N/A

**REQUIRED CHANGES TO WORK PROGRAMS:** N/A

**STAFF:** Power Department

**ATTACHMENTS:**

- Distribution Automation Presentation 2 (PDF)

**Review:**

- Hugh Richardson Completed 11/23/2021 10:29 AM
- Sonya Harold Completed 11/23/2021 11:45 AM
- Mercedes Miller Completed 11/23/2021 11:55 AM
- Mayor & City Council Pending 12/06/2021 6:00 PM



# Distribution Automation (DA) Project



# Introduction

- Distribution Automation is basically a self healing process during power outages.
- Strategically placed automatic switches on the power lines will restore as many customers as possible during a feeder outage.
- There are 3 basic stages of the system: detection, isolation, and restoration.



# Background

- College Park Power serves about 8400 customers from 8 different substations but 5 substations serve 98%.
- There are 27 circuits feeding the entire City area.
- All substations have re-feed options with 108 gang operated switches in place.

College Park Power Substation Information

MEAG #	Name	Peak MW	Capacity	% Capacity	Location	Circuits	Joint Use	Areas served
1	Harvard	13.1	44.8	29.2	North Center	6	no	North area of the City, GICC West +
2	Willingham	3.4	33.6	10.1	NE of City	1	East Point	Virginia Ave, Walker, Jackson +
3	Edison	21.2	33.6	63.1	South Center	8	GPC	Sullivan, Roosevelt, Best, Riverdale, Old Nat, GICC East, Data Center +
4	Lakemont	7.5	33.6	22.3	City west	3	East Point	Campcreek, Lakeshore, Herschel +
5	W. Fayetteville	18.6	67.2	27.7	City south	8	no	Godby, Southhampton, Riverdale, Data Center +
6	Ellenwood	1.2	60	2.0	Ellenwood	1	GPC	Fedex Ground
7	Jonesboro	0.4	50	0.8	Stockbridge	1	GPC	At Home store (Garden Ridge)
9B	Crystal Lake	2.7	7	38.6	Forest Pkwy	1	GPC	Phoenix Blvd., Backup to W. Fayetteville

1.1.a

Simple substation diagram with refeed options.

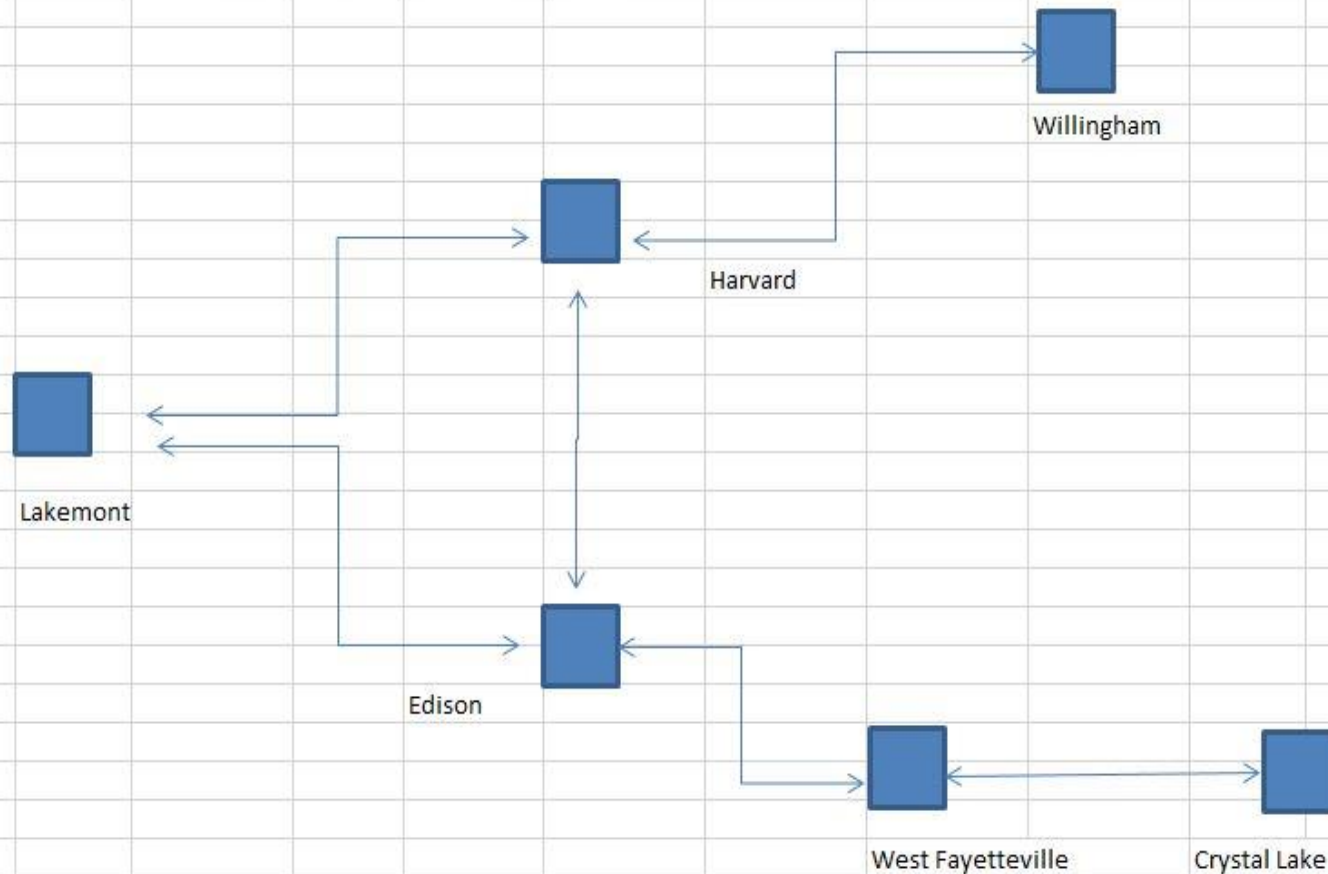



# Present vs DA Comparison (night outage)

## Present:

- Circuit locks out at a substation from a fallen tree.
- Crew is dispatched to find the fault = 40 minutes
- After fault is located and requires extensive repairs, crew moves to isolate fault = 15 minutes.
- Crew opens GOS #1 for section that has fault = 10 minutes
- Crew closes GOS #2 to pick up part of the circuit = 10 minutes
- Outage time for customers not on faulted section = 75 minutes





# Present vs DA Comparison

## Automated:

- Circuit locks out at a substation from a fallen tree.
- Fault indicators communicate with switching devices to determine location of fault. Auto switch #1 opens to isolate = 2 minutes
- Auto switch #2 closes to pick up customers not on faulted section = 30 seconds.
- Outage time for customers not on faulted section = 2.5 minutes



# Simulated Outage Restoration #1

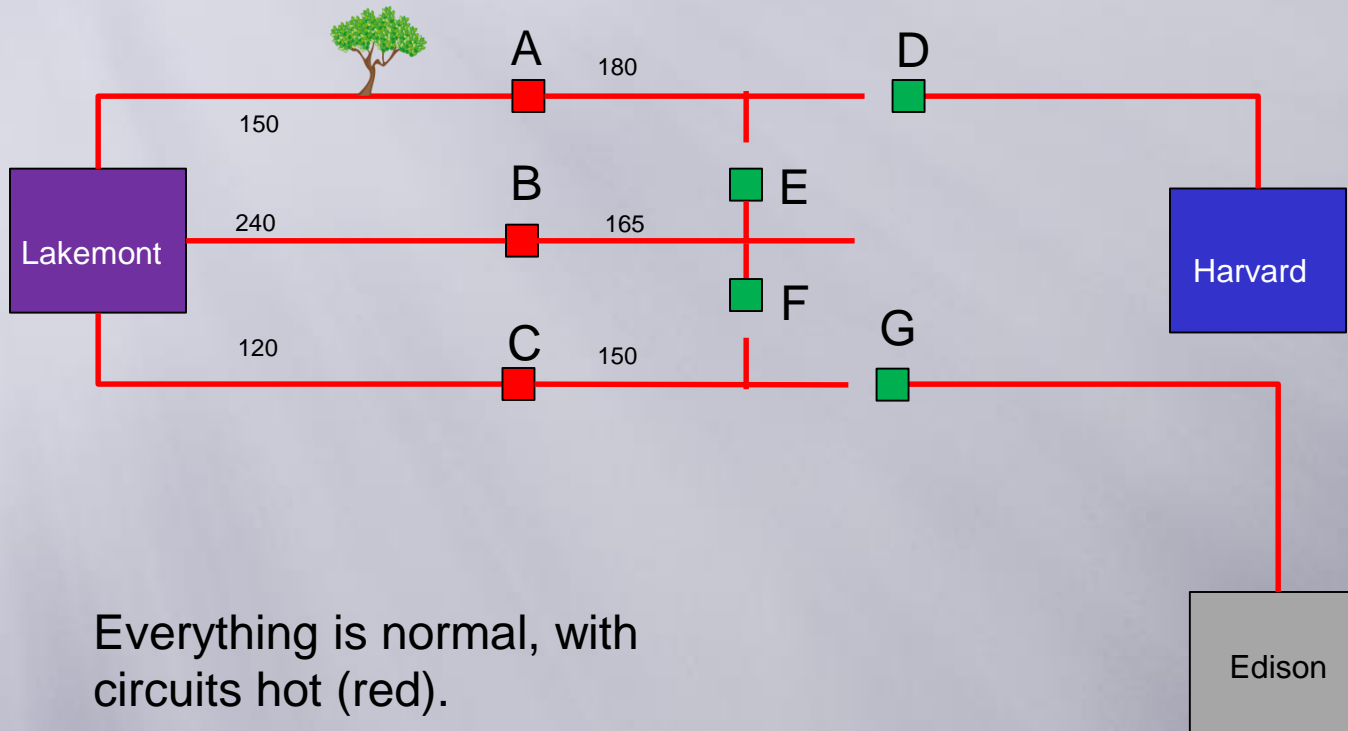

# Simulated Outage Restoration #1

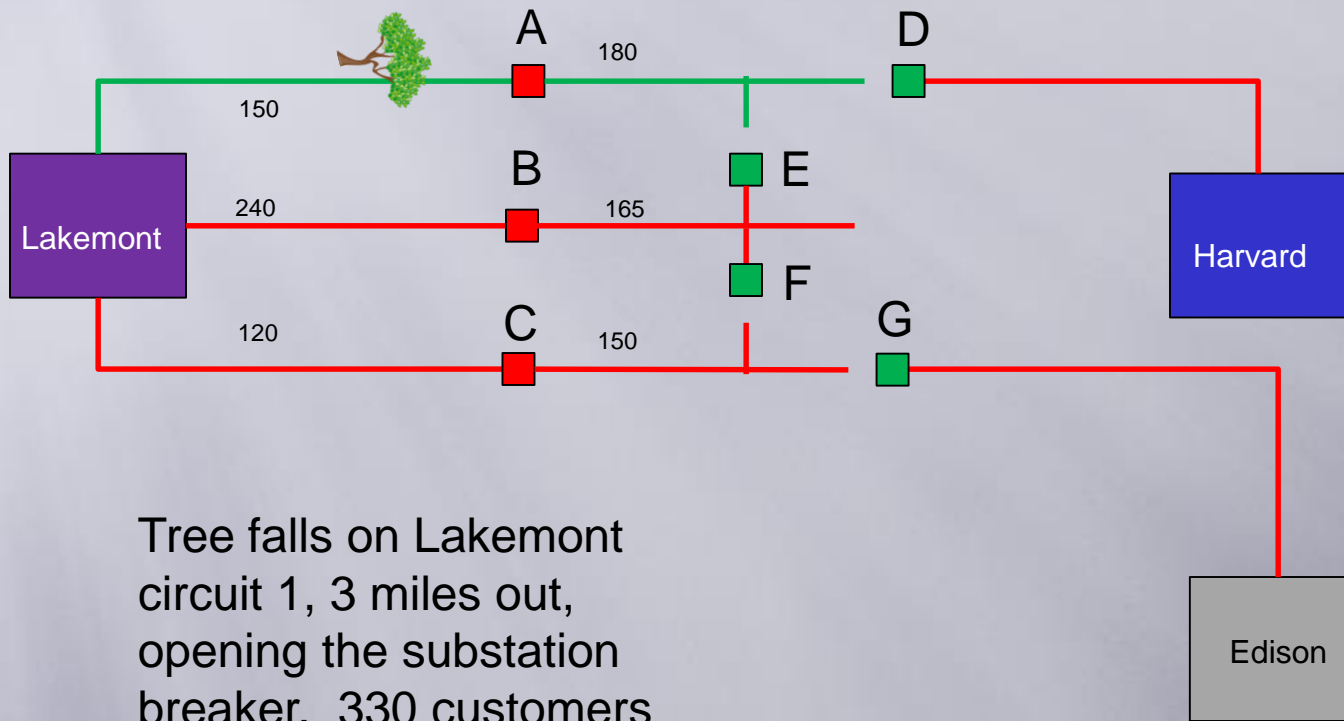

Tree falls on Lakemont circuit 1, 3 miles out, opening the substation breaker. 330 customers out.



# Simulated Outage Restoration #1

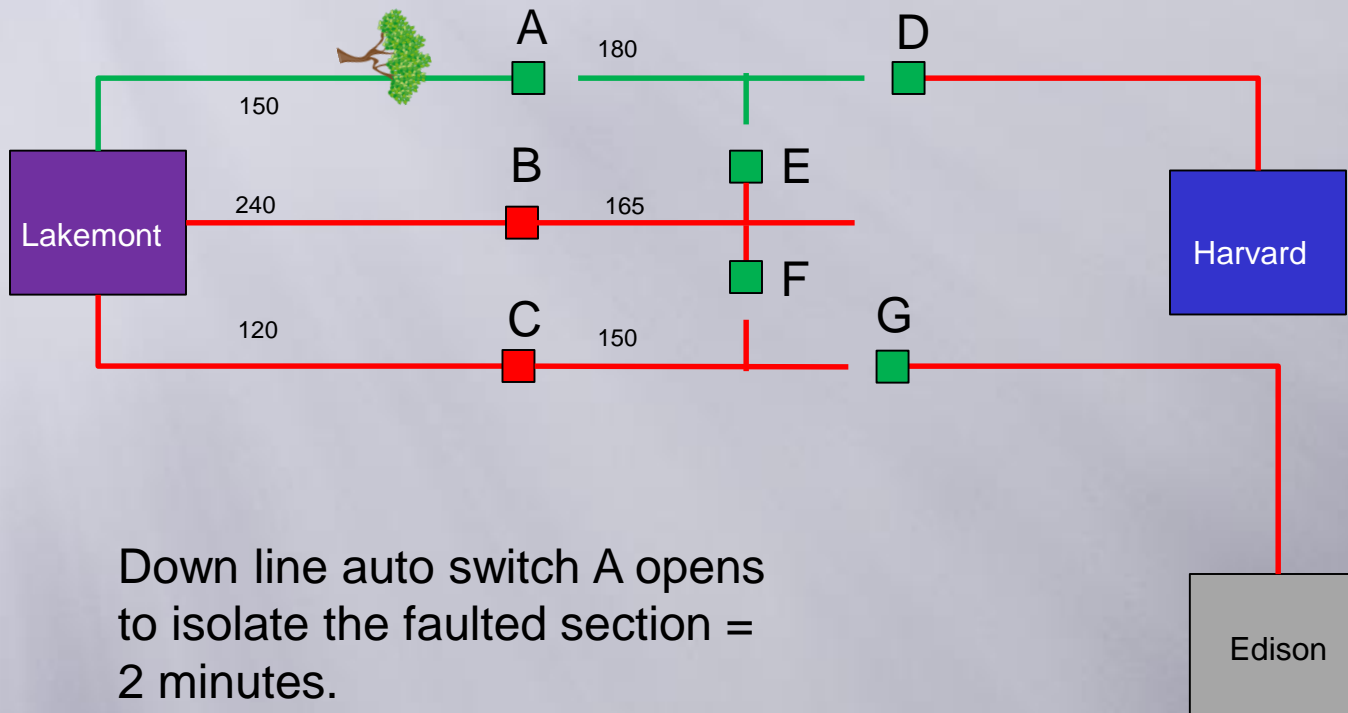



# Simulated Outage Restoration #1

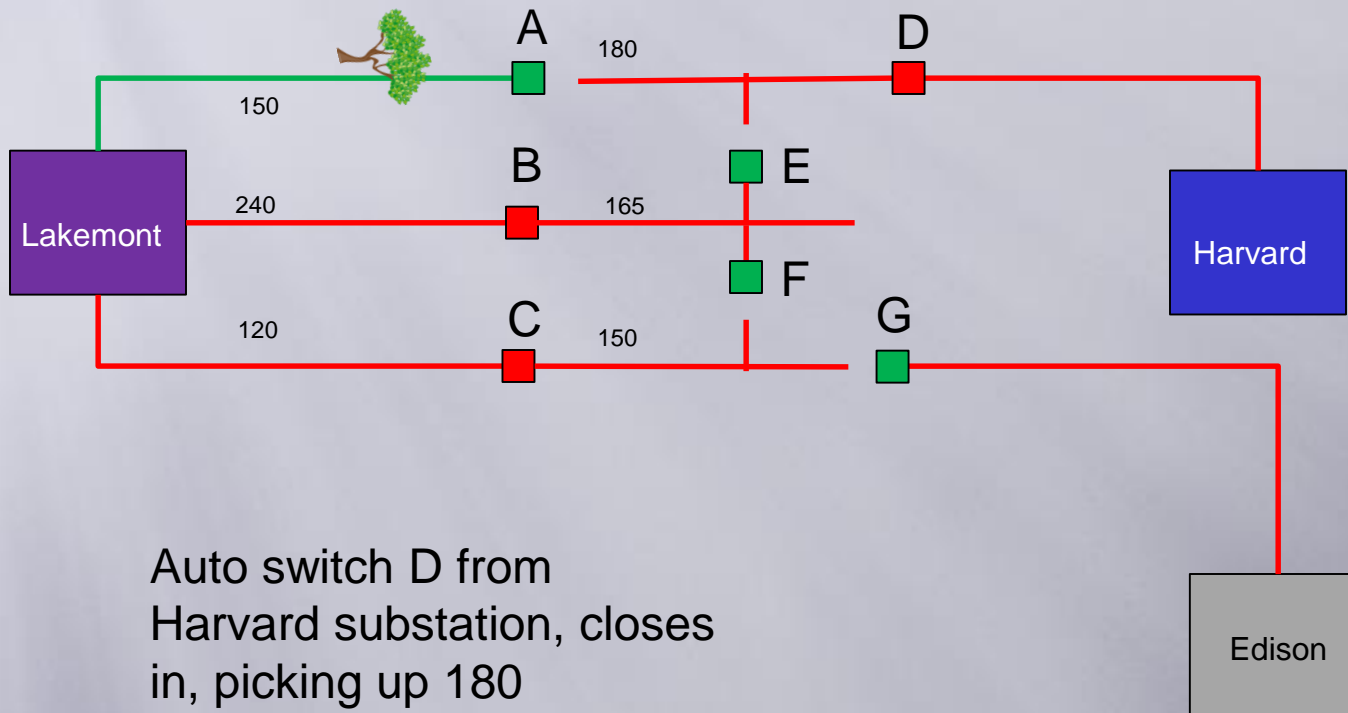

Auto switch D from Harvard substation, closes in, picking up 180 customers in less than 30 seconds = 2.5 minutes out.

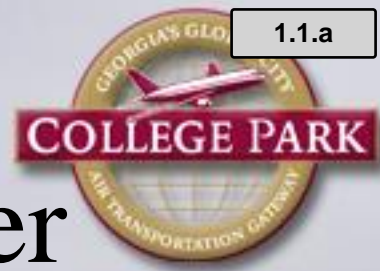

# Nova Controlled Recloser





# Schedule & Plan

- Initial installation will include 12 reclosers to protect 8 circuits.
- Heavy residential areas will be the first priority of protection
- Delivery of reclosers is 25 weeks: install in July – August 2022.
- Continue to budget more reclosers in 2023 and beyond to expand the protection.



# CITY OF COLLEGE PARK

P.O. BOX 87137 · COLLEGE PARK, GA 30337 · 404.767.1537

## WORKSHOP AGENDA ITEM

DOC ID: 9232

**DATE:** November 29, 2021

**TO:** The Honorable Mayor and Members of City Council

**THROUGH:** Mercedes Miller, Interim City Manager

**FROM:** Nikki Washington, City Planner

**RE:** Review of a Licensing Food Truck Ordinance

**PURPOSE:** Review of a Licensing Food Truck Ordinance. See memorandum dated November 29, 2021, from City Planner Nikki Washington.

**REASON:** Review of a Licensing Food Truck Ordinance.

**BACKGROUND:** In order to permit food trucks to operate within the City of College Park, a licensing code is needed to ensure proper operation. This ordinance would regulate food trucks within the City limits.

**RELATIONSHIP TO EXISTING ORDINANCE OR RESOLUTION:** This ordinance will regulate the licensing of food trucks within the City of College Park.

**STAFF:** Nikki Washington

### ATTACHMENTS:

- FoodTruckWorkshopOverview (PDF)
- College Park- Ordinance- Food Truck Nov. 2021 Final (PDF)

### Review:

- Nikki Washington Completed 11/23/2021 3:35 PM
- Sonya Harold Completed 11/29/2021 10:27 AM
- Shavala Moore Pending
- City Attorney's Office Completed 11/29/2021 10:54 AM
- Mercedes Miller Pending
- Mayor & City Council Pending 12/06/2021 6:00 PM





## Mobile Food Vendor Ordinance Highlights

- Mobile Food Vendors must receive a permit from City of College Park to operate within the City
- Special Event Permit needed to operate on public property
- May operate on Private property with consent of the owner given the following:
  - Mobile Food Vendors shall not be located within fifteen (15) feet of any street intersection or pedestrian crosswalk or ten (10) feet of any driveway.
  - Mobile Food Vendors shall not be located within two hundred (200) feet of a restaurant or a Food Retailer
  - Services between the hours of 10:00 p.m. to 9:00 a.m. only
  - Mobile Food Vendor may only sell food and non-alcoholic beverage items

**STATE OF GEORGIA  
CITY OF COLLEGE PARK**

**ORDINANCE NO. 2021-\_\_**

1 **AN ORDINANCE TO AMEND CHAPTER 11 (OCCUPATIONAL LICENSES, TAXES**  
 2 **AND REGULATIONS), ARTICLE VIII (PEDDLERS; TRANSIENT MERCHANTS;**  
 3 **SOLICITORS AND CANVASSERS) OF THE CITY OF COLLEGE PARK CODE OF**  
 4 **ORDINANCES TO REGULATE THE USE OF FOOD TRUCKS IN THE CITY OF**  
 5 **COLLEGE PARK; TO PROVIDE FOR SEVERABILITY; TO REPEAL CONFLICTING**  
 6 **ORDINANCES; TO PROVIDE AN ADOPTION DATE; TO PROVIDE AN EFFECTIVE**  
 7 **DATE; AND TO PROVIDE FOR OTHER LAWFUL PURPOSES.**

8 **WHEREAS**, the City of College Park, Georgia (the “City”) is a municipal corporation  
 9 created under the laws of the State of Georgia; and

10 **WHEREAS**, the duly elected governing authority of the City is the Mayor and Council  
 11 thereof; and

12 **WHEREAS**, the Charter of the City of College Park provides the City of College Park  
 13 with broad authority to regulate the use of public roadways in the City. College Park City Charter  
 14 Section 2-1; and

15 **WHEREAS**, “[t]he streets [and public ways] belong to the public and are primarily for the  
 16 use of the public in the ordinary way. Their use for the purposes of gain is special and  
 17 extraordinary, and, generally at least, may be prohibited or conditioned as the legislature deems  
 18 proper.” *Packard v. Banton*, 264 U.S.140, 144 (1924); *Schlesinger v. City of Atlanta*, 129 S.E. 861,  
 19 867 (1925) (individuals do not have the inherent right to conduct their private businesses in the  
 20 streets and public property of a city, and a city may prohibit such business activities); and

21           **WHEREAS**, Chapter 11 (Occupational Licenses, Taxes and Regulations) of the City  
22 Code of Ordinances (the “Code”) sets forth the procedures by which businesses may be taxed and  
23 regulated in the City; and

24           **WHEREAS**, Chapter 11, Article VIII (Peddlers; Transient Merchants; Solicitors and  
25 Canvassers) provides a framework for regulating businesses that do not operate from a fixed  
26 location; and

27           **WHEREAS**, mobile food vending is an increasingly popular line of business that will  
28 provide residents of the City ~~with~~ increased dining options; and

29           **WHEREAS**, after due consideration, the duly elected governing authority desires to permit  
30 limited operation of mobile food vendors in the City; and

31           **WHEREAS**, the City Council finds that it is necessary to amend the relevant provisions  
32 of Chapter 11, Article VIII of the Code ~~to~~ provide a regulatory framework for the limited operation  
33 of mobile food vendors in the City.

34

35           **BE IT AND IT IS HEREBY ORDAINED BY THE MAYOR AND COUNCIL OF**  
36 **THE CITY OF COLLEGE PARK, GEORGIA, and by the authority thereof:**

37

38           **Section 1.**     The Code of Ordinances, City of College Park, Georgia is hereby amended  
39 by revising Chapter 11, Article VIII, Section 11-140 (Definitions), to be read and codified as  
40 follows with added text in **bold** font and deleted text in strikethrough font:

41           “Sec. 11-140. - Definitions.

42           As used in this article, the following terms shall have the respective meanings  
43 ascribed to them:

44           (1) Transient merchant: Any person who sets up or displays merchandise for sale  
45 outside of a building on any lot where the person or entity setting up or displaying

46 such merchandise does not also lawfully conduct business regularly in a building  
47 located on that lot.

48 (2) Peddler: Any person who solicits, excluding, however:

49 a. Transient merchants;

50 b. Any person who sells agricultural, forestry or other farm products;

51 c. Any person who conducts business at any industry or association trade  
52 show;

53 d. Any person who sells items at a rummage, garage, antique or similar sale,  
54 or a flea market, where such sale is not part of the regular business activity  
55 of such person; and

56 e. Any person who exclusively donates the net proceeds of all sales or  
57 moneys otherwise obtained to one (1) or more nonprofit organizations.

58 (3) Solicit ~~To sell products or services, conduct nonprofit activities, or otherwise~~  
59 ~~represent an entity by traveling to customers' homes, places of business or other~~  
60 ~~places where customers are located.~~ **shall mean taking orders, selling, or seeking**  
61 **orders or clients for the purchase of goods, wares, merchandise, foodstuffs,**  
62 **products, subscriptions, or services of any kind, character, or description**  
63 **whatsoever.**

64 (4) Nonprofit organization: Any tax-exempt organization within the meaning of the  
65 Internal Revenue Code or the Georgia Income Tax Law, as such code and such law  
66 are now or may be hereafter amended.

67 (5) Nonprofit activities: Solicitation of funds or donations as a peddler or transient  
68 merchant for any nonprofit organization.

69 (6) Seasonal items: Christmas trees sold in October, November and December, and  
70 pumpkins sold in October.

71 (7) Special Events: Any event sponsored by the city, and any parade permitted by  
72 the city.

73 **(8) Mobile Food Vendor shall mean a motorized wheeled vehicle or a towed**  
74 **wheeled vehicle designed and equipped to serve food.**

75 **(9) Food Retailer shall mean a food establishment that sells to consumer**  
76 **customers food or food products intended for preparation or consumption off**  
77 **of the premises.**

80  
81 **Section 2.** The Code of Ordinances, City of College Park, Georgia is hereby amended

82 by revising Chapter 11, Article VIII to add a new Section 11-152, to be read and codified as follows

83 with added text in **bold** font and deleted text in strikethrough font:

84 **“Sec. 11-152 Regulation and Licensing of Mobile Food Vendors.**

85 (a) It shall be unlawful for any person to sell, or offer for sale, food of any type from  
86 a Mobile Food Vendor without a license first having been granted under this section,  
87 except for such activities conducted in connection with city-sponsored events.

88 (b) An application for a permit hereunder shall be submitted to the city clerk or his  
89 or her designee setting forth all information required hereunder and in compliance  
90 with this ordinance. The city clerk or his or her designee shall develop a form of  
91 application for the purpose of compliance with this article. The application shall be  
92 accompanied by an executed indemnity agreement indemnifying and releasing the  
93 city, its agents, employees and elected officials from any and all liability against any  
94 and all claims, actions and suits of any type whatsoever arising in connection with the  
95 activities of the Mobile Food Vendor pursuant to the permit issued hereunder.

96 (c) The following information shall be provided with each application for a Mobile  
97 Food Vendor permit, along with an executed Release and Indemnification Agreement  
98 provided by the city:

- 99 (1) Name of the Mobile Food Vendor;
- 100 (2) Make, model and license plate number of vending unit;
- 101 (3) Owner's contact information;
- 102 (4) Operator's contact information;
- 103 (5) Copy of approved permit from the Fulton County Health Department, or,  
104 if the Mobile Food Vendor will be operating in the portion of the city located  
105 in Clayton, County, the Clayton County Health Department;
- 106 (6) List of operating locations and times including map detailing the position  
107 of the vehicle, and current zoning in said locations;

108 (7) Signatures from property owners indicating consent for the use of their  
109 property; and

110 (8) Signature of applicant indicating agreement to the listed requirements.

111 (d) Mobile Food Vendors shall be licensed and taxed in accordance with the  
112 provisions of Section 11-145 of the City of College Park Code of Ordinances.

113 (e) No Mobile Food Vendor shall conduct business or operate in the public right-of-  
114 way or on public property (including, but not limited to, public parks or public  
115 recreation grounds of the city (as defined in Section 13-6(d) of the College Park Code  
116 of Ordinances)), without a special event permit. Mobile Food Vendors cannot be  
117 parked in the public right-of-way, on sidewalks, grass, or areas not intended for  
118 parking vehicles.

119 (f) Notwithstanding anything to the contrary in Section 13(b) of the College Park  
120 Code of Ordinances, persons who are not an employee, officer or agent of the city or  
121 a resident of the city may enter public parks or public recreation grounds of the city  
122 to make purchases from Mobile Food Vendors lawfully conducting business or  
123 operating in public parks or public recreation grounds of the city pursuant to a  
124 special event permit.

125 (g) A Mobile Food Vendor may operate on private property subject to the following:

126 (1) the owner must provide prior written consent; and

127 (2) the Mobile Food Vendor must operate in accordance with the distance  
128 requirements set forth in Section 11-152(m).

129 A Mobile Food Vendor shall not be allowed to park overnight on any private property  
130 without the prior written consent of the owner.

131 (h) Notwithstanding anything in this article to the contrary, a Mobile Food Vendor  
132 shall maintain a one million dollar (\$1,000,000.00) liability insurance policy. Proof of  
133 current liability insurance, issued by an insurance company licensed to do business in  
134 Georgia, protecting the Mobile Food Vendor, the public and the city from all claims  
135 for damage to property and bodily injury, including death, which may arise from  
136 operation under or in connection with the permit, shall be provided to the city as part  
137 of its permit application. If the Mobile Food Vendor does not have insurance, the  
138 Mobile Food Vendor may be under the umbrella of an existing business with the  
139 business' permission to do so. Such arrangement documentation shall be included  
140 with the application to the city.

141 (i) A Mobile Food Vendor shall not make sounds or announcements to call attention  
142 to the mobile food vehicle either while traveling on the public rights-of-way or when  
143 stationary. At all times said Mobile Food Vendor shall be in compliance with the city's  
144 noise ordinance.

145 (j) The license under which a Mobile Food Vendor is operating must be firmly  
146 attached and visible on the Mobile Food Vendor at all times.

147 (k) Any driver of a Mobile Food Vendor motorized vehicle must possess a valid  
148 Georgia driver's license.

149 (l) Mobile Food Vendors shall not be located within fifteen (15) feet of any street  
150 intersection or pedestrian crosswalk or ten (10) feet of any driveway.

151 (m) Mobile Food Vendors shall not be located within two hundred (200) feet of a  
152 restaurant or a Food Retailer. Notwithstanding the foregoing:

153 (1) **If a restaurant (or the corporate entity that owns the restaurant) owns a**  
154 **Mobile Food Vendor, the Mobile Food Vendor may be located within two**  
155 **hundred (200) feet of that restaurant; or**

156 (2) **If a Mobile Food Vendor is operating pursuant to a special event permit,**  
157 **the Mobile Food Vendor may be located within two hundred (200) feet of a**  
158 **restaurant or a Food Retailer.**

159 (n) **A Mobile Food Vendor shall not sell or offer to sell any goods, foods, products, or**  
160 **services between the hours of 10:00 p.m. to 9:00 a.m.**

161 (o) **Vending structures shall not be left unattended or stored at any time on the open**  
162 **vending site when vending is not taking place or during restricted hours of operation.**

163 (p) **Mobile Food Vendors shall comply with all state, federal and local health and**  
164 **safety regulations and requirements and shall obtain and maintain any and all**  
165 **licenses required by any other health organization or governmental organization**  
166 **having jurisdiction over this subject matter.**

167 (q) **The following safety regulations shall apply to any and all vehicles operating under**  
168 **this article or used for mobile retail food establishments:**

169 (1) **Every vehicle shall be equipped with a reverse gear signal alarm with a**  
170 **sound distinguishable from the surrounding noise level.**

171 (2) **Every vehicle shall be equipped with two (2) rear-vision mirrors, one (1) at**  
172 **each side, firmly attached to the outside of the motor vehicle, and so located as**  
173 **to reflect to the driver a view of the highway to the rear, along both sides of**  
174 **the vehicle.**



175 (r) A Mobile Food Vendor may only sell food and non-alcoholic beverage items.  
176 Notwithstanding the foregoing, a Mobile Food Vendor may offer alcoholic beverages  
177 for sale if the Mobile Food Vendor is licensed to sell alcoholic beverages in accordance  
178 with the applicable provisions of the City of College Park Code of Ordinances.  
179 Alcoholic beverages offered for sale by a Mobile Food Vendor may be consumed in  
180 public areas subject to the following conditions:

181 (i) If the alcoholic beverage is consumed in accordance with the provisions of  
182 Section 3-3 of the City of College Park Code of Ordinances; or

183 (ii) If the alcoholic beverage is consumed in such public areas as may be  
184 designated by the city as permissible for public consumption of alcohol.

185 **Section 3.** The preamble of this Ordinance shall be considered to be and is hereby  
186 incorporated by reference as if fully set out herein.

187 **Section 4.** (a) It is hereby declared to be the intention of the Mayor and Council that  
188 all sections, paragraphs, sentences, clauses and phrases of this Ordinance are or were, upon their  
189 enactment, believed by the Mayor and Council to be fully valid, enforceable and constitutional.

190 (b) It is hereby declared to be the intention of the Mayor and Council that, to the  
191 greatest extent allowed by law, each and every section, paragraph, sentence, clause or phrase of  
192 this Ordinance is severable from every other section, paragraph, sentence, clause or phrase of this  
193 Ordinance. It is hereby further declared to be the intention of the Mayor and Council that, to the  
194 greatest extent allowed by law, no section, paragraph, sentence, clause or phrase of this Ordinance  
195 is mutually dependent upon any other section, paragraph, sentence, clause or phrase of this  
196 Ordinance.

197 (c) In the event that any phrase, clause, sentence, paragraph or section of this  
198 Ordinance shall, for any reason whatsoever, be declared invalid, unconstitutional or otherwise  
199 unenforceable by the valid judgment or decree of any court of competent jurisdiction, it is the  
200 express intent of the Mayor and Council that such invalidity, unconstitutionality or  
201 unenforceability shall, to the greatest extent allowed by law, not render invalid, unconstitutional  
202 or otherwise unenforceable any of the remaining phrases, clauses, sentences, paragraphs or  
203 sections of this Ordinance and that, to the greatest extent allowed by law, all remaining phrases,  
204 clauses, sentences, paragraphs and sections of this Ordinance shall remain valid, constitutional,  
205 enforceable, and of full force and effect.

206 **Section 5.** All ordinances and parts of ordinances in conflict herewith are hereby expressly  
207 repealed to the extent they conflict with this Ordinance.

208 **Section 6.** The effective date of this Ordinance shall be the date of adoption unless  
209 otherwise specified herein.

**ORDAINED** this \_\_\_ day of \_\_\_\_\_, 2021.

**CITY OF COLLEGE PARK, GEORGIA**

\_\_\_\_\_  
**BIANCA MOTLEY BROOM, Mayor**

**ATTEST:**

\_\_\_\_\_  
**SHAVALA MOORE, City Clerk**

**APPROVED AS TO FORM:**

\_\_\_\_\_

City Attorney

